

**CHARTER TOWNSHIP OF JAMESTOWN**  
**COUNTY OF OTTAWA, MICHIGAN**

At a regular meeting of the Township Board of the Charter Township of Jamestown, held at the Township Hall, on the 18th day of September 2023, at 7:00 p.m.

PRESENT: Members: VanHaitsma, Brouwer, DeHaan, Miedema, Miller, Tacoma

ABSENT: Members: McCormick

It was moved by DeHaan and seconded by Miedema that the following Ordinance be adopted under authority of the Revenue Bond Act of 1933, being Act 94 of the Public Acts of Michigan of 1933, as amended.

**ORDINANCE NO. 23-003**

**AN ORDINANCE TO REGULATE THE USE OF PUBLIC AND PRIVATE SEWERS AND DRAINS, PRIVATE SEWAGE DISPOSAL, THE INSTALLATION AND CONNECTION OF BUILDING SEWERS, AND THE DISCHARGE OF WATERS AND WASTES INTO PUBLIC SEWAGE DISPOSAL FACILITIES IN THE TOWNSHIP; TO PROVIDE FOR THE CONNECTION TO AND THE FIXING AND COLLECTION OF RATES AND CHARGES FOR THE USE OF THE SEWAGE SYSTEM, THE ALLOCATION AND USE OF REVENUES DERIVED THEREFROM AND THE ADMINISTRATION OF THE SYSTEM; AND TO PROVIDE PENALTIES FOR ORDINANCE VIOLATIONS AND OTHER MATTERS PERTAINING THERETO**

The Ordinance was then discussed.

Upon roll call vote, the vote upon the motion adopting said Ordinance was as follows:

YEAS: Members: Miller, Miedema, DeHaan, VanHaitsma, Brouwer, Tacoma

NAYS: Members: None

The Township Clerk declared the Ordinance adopted.

The following is Ordinance No. 23-003 as adopted:

## Table of Contents

Article I SHORT TITLE; FINDINGS; PURPOSE .....	1
Section 101. Short Title .....	1
Section 102. Objectives Re: Contract Requirements .....	1
Section 103. Objectives Re: State and Federal Law Requirements .....	1
Section 104. Findings Re: Public Health, Safety and Welfare .....	2
Section 105. Finding Re: Measure of Sewer Use by Sewer Metering or Metering of Water Supply .....	2
Article II DEFINITIONS .....	2
Section 201. Availability Fee .....	2
Section 202. Available Public Sanitary Sewer System .....	3
Section 203. B.O.D. or Biochemical Oxygen Demand .....	3
Section 204. Bond Contract .....	3
Section 205. Building Drain .....	3
Section 206. Building Sewer .....	3
Section 207. C.O.D. or Chemical Oxygen Demand .....	3
Section 208. City or Grandville .....	3
Section 209. Commodity Fee .....	3
Section 210. Compatible Pollutant .....	3
Section 211. Connection Fee .....	4
Section 212. Cost of Operation and Maintenance .....	4
Section 213. Cost of Replacement .....	4
Section 214. County .....	4
Section 215. Debt Service Charge .....	4
Section 216. Discharge Permit .....	4
Section 217. Domestic Sewage .....	4
Section 218. Dwelling Unit .....	4
Section 219. EGLE .....	4
Section 220. Garbage .....	5
Section 221. Grandville Contract .....	5
Section 222. Gravity System .....	5
Section 223. Grinder Pump .....	5
Section 224. Grinder Pump System .....	5
Section 225. Health Department .....	5
Section 226. Industrial Users .....	5
Section 227. Industrial Wastes .....	5
Section 228. Inspection and Administration Fee .....	5
Section 229. Inspector .....	5
Section 230. Lateral Charge .....	5
Section 231. May .....	5
Section 232. MG/L .....	5
Section 233. Miscellaneous User Fee .....	6
Section 234. Natural Outlet .....	6
Section 235. Normal Strength .....	6
Section 236. Nuisance .....	6
Section 237. pH .....	6
Section 238. PPM .....	6
Section 239. Person .....	6

Section 240.	Properly Shredded Garbage .....	6
Section 241.	Public Sewer System or System .....	6
Section 242.	Readiness to Serve Charge.....	6
Section 243.	Residential Equivalent Unit or Units .....	6
Section 244.	Sampling Manhole .....	7
Section 245.	Septic Tank .....	7
Section 246.	Service Connection .....	7
Section 247.	Service District.....	7
Section 248.	Sewage Disposal Facilities .....	7
Section 249.	Sewage Treatment Facility .....	7
Section 250.	Sewage .....	7
Section 251.	Sewage Treatment Plant Connection Fee .....	7
Section 252.	Sewer Lead.....	7
Section 253.	Sewer Rates and Charges .....	7
Section 254.	Shall .....	8
Section 255.	Slug .....	8
Section 256.	Special Assessment District.....	8
Section 257.	Special Assessment Roll .....	8
Section 258.	STED System.....	8
Section 259.	STEP System .....	8
Section 260.	Structure in which Sanitary Sewage Originates.....	8
Section 261.	Storm Sewer or Storm Drain.....	8
Section 262.	Subsurface Disposal System .....	8
Section 263.	Superintendent .....	8
Section 264.	Supervisor .....	8
Section 265.	S.S. or Suspended Solids .....	8
Section 266.	System Septic Tank.....	8
Section 267.	Township.....	8
Section 268.	Township Engineer .....	9
Section 269.	Trunkage Charge.....	9
Section 270.	Twenty-five Percent Rule or 25% Rule .....	9
Section 271.	U.S. EPA.....	9
Section 272.	User .....	9
Section 273.	User Charge .....	9
Section 274.	User Class .....	9
Section 275.	User Surcharge.....	10
Section 276.	Watercourse .....	10
Article III	USE OF PUBLIC SEWER SYSTEM REQUIRED .....	10
Section 301.	Discharge of Sewage.....	10
Section 302.	Sewage Disposal Facilities .....	10
Section 303.	Mandatory Connection of Properties in Special Assessment District .....	10
Section 304.	Connection of Existing Improved Properties in Service District Outside Special Assessment District .....	10
Section 305.	Connection Deadline.....	10
Section 306.	Enforcement in the Event of a Failure to Connect.....	11
Section 307.	Extensions of Public Sewer System to Service New Developments .....	11
Section 308.	Connection of Premises Located Outside the Service District .....	11

Section 309.	Conditions for Extension of Public Sewer System by Property Owner.....	12
Section 310.	Sewer Extension Agreements .....	13
Article IV	PRIVATE SEWAGE DISPOSAL.....	13
Section 401.	Private Sewage Disposal Facilities .....	13
Section 402.	Operation and Maintenance .....	13
Section 403.	Governmental Requirements .....	13
Section 404.	Connection to Public Sewer System; Abandonment .....	13
Article V	BUILDING SEWERS AND CONNECTIONS.....	14
Section 501.	Permit Requirement .....	14
Section 502.	Permit Application.....	14
Section 503.	Approval of Application .....	14
Section 504.	Excavations, Pipe Laying and Backfill.....	14
Section 505.	Connection of Building Sewer.....	14
Section 506.	Connection of Certain Drains is Prohibited.....	15
Section 507.	Public Safety Requirements; Restoration .....	15
Section 508.	Cost of Installation of Building Sewer and Connection to Public Sewer; Indemnification.....	15
Section 509.	Inspection.....	15
Section 510.	Township’s Responsibility for Repairs, Operation and Maintenance .....	15
Section 511.	Property Owner’s Responsibility for Repairs, Operation and Maintenance.....	15
Article VI	USE OF THE PUBLIC SEWER SYSTEM .....	16
Section 601.	Prohibited Discharge of Storm Water.....	16
Section 602.	Permissible Discharge of Storm Water.....	16
Section 603.	Prohibited Discharges to Public Sewer System.....	16
Section 604.	Discharge Permit Limitations .....	17
Section 605.	Remedies; Pre-Treatment.....	18
Section 606.	Maintenance of Pre-Treatment Facilities.....	18
Section 607.	Special Arrangements; Surcharge.....	18
Section 608.	Grease, Oil and Sand Interceptors .....	18
Section 609.	Sampling Manhole .....	20
Section 610.	Testing of Industrial Wastes .....	20
Section 611.	Test Standards.....	20
Section 612.	Industrial Users; Permits; Information Required; Records.....	21
Section 613.	Maintenance of Records .....	25
Article VII	SEWER RATES AND CHARGES .....	25
Section 701.	Public Utility Basis; Fiscal Year.....	25
Section 702.	Connection Fee .....	25
Section 703.	User Charge .....	26
Section 704.	User Surcharge.....	27
Section 705.	Miscellaneous User Fee .....	27
Section 706.	Inspection and Administration Fee .....	27
Section 707.	Billing of Sewer Rates and Charges .....	27
Section 708.	Unpaid Sewer Rates and Charges; Penalty.....	28
Section 709.	Unpaid Sewer Rates and Charges; Remedies .....	28
Section 710.	Lien .....	29

Section 711. No Free Service.....	29
Section 712. Rental Properties.....	29
Section 713. Cancellation of Permits; Disconnection of Service .....	29
Section 714. Security Deposit.....	30
Section 715. Billing Address .....	30
Section 716. Interruption of Service; Claims.....	30
Article VIII REVENUES.....	31
Section 801. Estimated Rates; Sufficiency .....	31
Section 802. Revenues; Depository .....	31
Section 803. Transfer of Funds.....	32
Section 804. Investment of Funds.....	32
Article IX ADMINISTRATIVE APPEALS; BOARD OF APPEALS .....	33
Section 901. Informal Hearing.....	33
Section 902. Board of Appeals .....	33
Section 903. Appeals from Informal Hearing.....	33
Section 904. Payment of Amounts Outstanding.....	34
Section 905. Effect of Administrative Action.....	34
Section 906. Appeal from Board of Appeals.....	34
Article X NOTICE AND CLAIM PROCEDURES FOR SEWER OVERFLOW OR BACKUP	34
Section 1001. Notice and Claim Procedures Applicable to Overflow or Backup of the Public Sewer System.....	34
Article XI ENFORCEMENT.....	36
Section 1101. Inspection by Township.....	36
Section 1102. Damage to System .....	37
Section 1103. Notice to Cease and Desist .....	37
Section 1104. Civil Infraction.....	37
Section 1105. Nuisance; Abatement .....	37
Section 1106. Liability for Expenses.....	37
Section 1107. Remedies are Cumulative .....	37
Article XII MISCELLANEOUS.....	38
Section 1201. Repeal of Conflicts .....	38
Section 1202. Severability .....	38
Section 1203. State and Federal Law Requirements .....	38
Section 1204. Article and Section Headings.....	38
Section 1205. Reservation of Right to Amend .....	38
Article XIII PUBLICATION AND EFFECTIVE DATE .....	38
Section 1301. Publication .....	38
Section 1302. Effective Date .....	38

**THE CHARTER TOWNSHIP OF JAMESTOWN ORDAINS:**

**ORDINANCE NO. 23-\_\_**

**AN ORDINANCE TO REGULATE THE USE OF PUBLIC AND PRIVATE SEWERS AND DRAINS, PRIVATE SEWAGE DISPOSAL, THE INSTALLATION AND CONNECTION OF BUILDING SEWERS, AND THE DISCHARGE OF WATERS AND WASTES INTO PUBLIC SEWAGE DISPOSAL FACILITIES IN THE TOWNSHIP; TO PROVIDE FOR THE CONNECTION TO AND THE FIXING AND COLLECTION OF RATES AND CHARGES FOR THE USE OF THE SEWAGE SYSTEM, THE ALLOCATION AND USE OF REVENUES DERIVED THEREFROM AND THE ADMINISTRATION OF THE SYSTEM; AND TO PROVIDE PENALTIES FOR ORDINANCE VIOLATIONS AND OTHER MATTERS PERTAINING THERETO**

**ARTICLE I  
SHORT TITLE; FINDINGS; PURPOSE**

**Section 101. Short Title.** This Ordinance shall be known as the “Sewer Connection, Use and Rate Ordinance” and may be cited as such.

**Section 102. Objectives Re: Contract Requirements.** This Ordinance is adopted in accordance with and in furtherance of the Township’s obligations as set forth in various agreements relating to public sanitary sewer service in the Township including, but not limited to, that certain the Grandville Contract (as defined in Section 221) and various contracts entered into from time to time by and between the Township and the County, with respect to the financing of improvements to the Public Sewer System (as defined in Section 204, the “Bond Contract”).

It is the purpose of the Township by enacting and keeping in force and effect this Ordinance to comply with the foregoing requirements of the Bond Contract and the Grandville Contract and to protect and promote the health and welfare of the residents of the Township.

**Section 103. Objectives Re: State and Federal Law Requirements.** This Ordinance sets forth uniform requirements for Users of the Public Sewer System and enables the Township to comply with all applicable State and Federal laws, including the Clean Water Act (33 United States Code § 1251 et seq.). In addition, the objectives of this Ordinance include the following:

- a. To prevent the introduction of pollutants into the Public Sewer System which will interfere with the operation of the System or contaminate the resulting sludge;
  - b. To prevent the introduction of pollutants into the Public Sewer System which will pass through the System, inadequately treated, into the receiving stream or the atmosphere or otherwise be incompatible with the Public Sewer System;
  - c. To improve the opportunity to recycle and reclaim wastewaters and sludges from the Public Sewer System;
  - d. To provide for equitable distribution of the cost of the Public Sewer System;
- and

e. To protect the physical integrity of the Public Sewer System and the Sewage Treatment Facility and to provide for the safety of the public and workers on and in the Public Sewer System and the Sewage Treatment Facility.

**Section 104. Findings Re: Public Health, Safety and Welfare.** The Township hereby determines that the Public Sewer System is immediately necessary to protect and preserve the public health, safety and welfare of the Township. This determination is based upon the express determination of the State Legislature set forth in Section 12752 of the Michigan Public Health Code and which reads as follows:

“Sec. 12752. Public sanitary sewer systems are essential to the health, safety, and welfare of the people of the state. Septic tank disposal systems are subject to failure due to soil conditions or other reasons. Failure or potential failure of septic tank disposal systems poses a threat to the public health, safety, and welfare; presents a potential for ill health, transmission of disease, mortality, and economic blight; and constitutes a threat to the quality of surface and subsurface waters of this state. The connection to available public sanitary sewer systems at the earliest, reasonable date is a matter for the protection of the public health, safety, and welfare and necessary in the public interest which is declared as a matter of legislative determination.”

**Section 105. Finding Re: Measure of Sewer Use by Sewer Metering or Metering of Water Supply.** The Township hereby finds that the metering of sewage flow through a sewage meter (if practicable and as determined by the Township) or metering of domestic water supply is the best available technology and preferred method for measuring with relative precision the discharge to and the use of the Public Sewer System. However, some users of the Public Sewer System are not customers of the Township’s public water system. Until such time as all customers of the Public Sewer System are also customers of the Township’s public water system, the Township finds that, with respect to such customers without a metered water supply, the use of a flat-rate User Charge based upon Units is a valid, cost effective, and practical method for measuring use of the Public Sewer System, particularly with respect to detached single family residential users.

## **ARTICLE II DEFINITIONS**

Unless the context specifically indicates otherwise, the meaning of terms used in this Ordinance shall be as follows:

**Section 201. Availability Fee.** A component of the Connection Fee imposed for the availability of the sewer main for a sewer connection, regardless of whether a sewer connection is actually made, which is based on the lineal frontage of the Premises along an existing or future sewer main. All properties with 150 feet or less of frontage shall pay an Availability Charge (Base). Premises with more than 150 feet of frontage shall pay the Availability Charge (Base) plus an Availability Charge (Per Foot). The Availability Fee (Per Foot) shall not be imposed for the first 150 feet of frontage of the Premises. For Premises with more than 150 feet of frontage, the Township Board shall establish the charge on a front-foot basis by resolution from time to time

and such front-foot charge shall be charged for all frontage that is functionally utilized. For purposes of this Section, “functionally utilized” means that portion of the frontage of the Premises that is occupied by buildings or structures; recreational facilities including, but not limited to, swimming pools; drives and parking area; grass and other landscaping; and/or other site improvements. With respect to the connection of a residential dwelling and/or farm buildings on a farm, farmland devoted to the raising of animals or crops or left fallow shall not be considered to be functionally utilized for purposes of the calculation of the Availability Charge (Per Foot). In order to exclude frontage from the calculation of the Availability Charge (Per Foot), the frontage which is not functionally utilized must meet the minimum zoning ordinance requirements for a buildable lot in the zoning district in which the Premises is located. Frontage in excess of 150 feet that is not functionally utilized shall be considered “deferred frontage” and shall be subject to connection charges including, but not limited to, a Availability Charge (Base) or (Per Foot) at such time as an application for building or zoning permit is submitted for improvements to be located on the land with the deferred frontage. If the Premises is a corner lot, the side yard frontage is permanently deferred for 150 feet. For side yard frontage in excess of 150 feet, the Premises shall pay the Availability Charge (Per Foot) for any frontage in excess of 150 feet.

**Section 202. Available Public Sanitary Sewer System.** A public sanitary sewer system (tapped or untapped) with sufficient capacity and ability to serve via a Gravity System that is located in a right of way, easement, highway, street, or public way which passes not more than 200 feet at the nearest point from a Structure in which Sanitary Sewage Originates.

**Section 203. B.O.D. or Biochemical Oxygen Demand.** As used in this Ordinance, the quantity of oxygen utilized in the biochemical oxidation of organic matter under standard laboratory procedures in five (5) days at 20°C., expressed in PPM by weight.

**Section 204. Bond Contract.** Any existing or future contract by and between the Township and the County (and others) relating to the financing of the construction and improvement of, and extensions to the System, as subsequently amended or otherwise revised.

**Section 205. Building Drain.** That part of the lowest horizontal piping of a drainage system which receives the discharge of Sewage inside of the walls of the building and extending five feet from the exterior wall, which conveys said discharge to the Building Sewer.

**Section 206. Building Sewer.** The extension from the Building Drain which conveys the discharge of Sewage to the Public Sewer System and its components or other place of disposal.

**Section 207. C.O.D. or Chemical Oxygen Demand.** The oxygen consuming capacity of inorganic and organic matter present in Sewage.

**Section 208. City or Grandville.** The City of Grandville, Kent County, Michigan.

**Section 209. Commodity Fee.** A component of the User Charge attributable to the cost charged by the Township for the treatment of Sewage by the Sewage Treatment Facility.

**Section 210. Compatible Pollutant.** The pollutants which can be treated and removed to a substantial degree by the Sewage Treatment Facility. These pollutants include but are not limited to defined maximum concentrations of B.O.D., S.S., pH and additional pollutants identified



in the Discharge Permit if the Sewage Treatment Facility was designed to treat such pollutants, and in fact does remove such pollutant to a substantial degree.

**Section 211. Connection Fee.** The charge imposed by the Township to regulate the connection of a Building Sewer, either directly or indirectly, to the Public Sewer System. This fee represents (a) the proportional cost attributable to each Structure in which Sanitary Sewage Originates to regulate access to the Public Sewer System and ensures that sufficient capacity exists to accommodate the additional use without overburdening the Public Sewer System or adversely affecting the Township's ability to provide service to the Public Sewer System's existing customers and (b) the benefit to the owner of a Structure in which Sanitary Sewage Originates derived from the connection to the Public Sewer System including, but not limited to, eliminating or reducing the risk of failure of private Sewage Disposal Facilities and the contamination of ground water. The Connection Fee includes the Availability Fee, the Lateral Charges, and the Sewage Treatment Plant Connection Fee, which is determined by the City in accordance with the Grandville Contract.

**Section 212. Cost of Operation and Maintenance.** All costs, direct and indirect, inclusive of all expenditures attributable to administration, Cost of Replacement, treatment and collection of Sewage, necessary to insure adequate collection and treatment of Sewage on a continuing basis in conformance with the Discharge Permit, and other applicable local, state and federal regulations.

**Section 213. Cost of Replacement.** Expenditures and costs for obtaining and installing equipment, accessories or appurtenances which are necessary during the service life of the System to maintain the capacity and performance for which the System was designed and constructed.

**Section 214. County.** The County of Ottawa, Michigan, acting by and through its Road Commission, the designated County Agency under Act 342 of the Public Acts of Michigan of 1939, as amended.

**Section 215. Debt Service Charge.** A component of the User Charge that represents the amount charged to Users of the Public Sewer System to pay all or a portion of the principal, interest and administrative costs of retiring the debt incurred for the acquisition and construction of improvements to or expansion of the Public Sewer System.

**Section 216. Discharge Permit.** Permit issued by EGLE for the discharge of treated Sewage from the Sewage Treatment Facility.

**Section 217. Domestic Sewage.** The liquid wastes from all habitable buildings and residences and shall include human excreta and wastes from sinks, lavatories, bathtubs, showers, laundries and all other water-carried wastes of organic nature either singly or in combination thereof.

**Section 218. Dwelling Unit.** For purposes of assigning units, a "dwelling" unit shall contain, at a minimum: sleeping facilities, a toilet, bath or shower and a kitchen.

**Section 219. EGLE.** The Michigan Department of Environment, Great Lakes, and Energy, or its successor agency.

**Section 220. Garbage.** Solid wastes from the preparation, cooking and dispensing of food, and the handling, sale and storage of produce and, in addition, shall include all paper, plastic and other household items, including containers, whether or not disposable or biodegradable in nature.

**Section 221. Grandville Contract.** The Amended and Restated Sewage Disposal Agreement (adoption version dated as of July 24, 2023 and effective as of September 25, 2023), by and between Grandville, the Charter Township of Georgetown, Ottawa County, Michigan, the City of Hudsonville, Ottawa County, Michigan, the County and the Township, which provides for the treatment of sewage from the Public Sewer System by Grandville.

**Section 222. Gravity System.** The publicly-owned gravity Sewer Lead which provides the connection between the privately-owned Building Sewer and the Public Sewer System. A diagram of a typical Gravity System is attached to this Ordinance as Appendix II-A.

**Section 223. Grinder Pump.** In a Grinder Pump System, the device to which the Building Sewer connects and which grinds and pumps the Sewage to the Public Sewer System for transportation to the Sewage Treatment Facility.

**Section 224. Grinder Pump System.** The privately-owned Grinder Pump, controls and pressure discharge pipe, including all control boards, controls, floats, pumps, storage tanks and appurtenances thereto which provides the connection between the privately-owned Building Sewer and the Public Sewer System. A diagram of a typical Grinder Pump System is attached to this Ordinance as Appendix II-B.

**Section 225. Health Department.** Ottawa County Health Department.

**Section 226. Industrial Users.** Users which discharge Industrial Wastes.

**Section 227. Industrial Wastes.** The liquid wastes, solids or semisolids from industrial, manufacturing, trade or business processes as distinct from Domestic Sewage.

**Section 228. Inspection and Administration Fee.** The amount charged, to each applicant by the Township at the time an application is made to the Township for connection to the Public Sewer System, to cover the routine cost of inspecting and approving the physical connection of a Building Sewer and Service Connection to the Public Sewer System, the issuance of a connection permit and related administrative expenses.

**Section 229. Inspector.** The persons responsible for inspecting connections of the Building Sewer, Service Connection, and extensions or improvements to the Public Sewer System as designated by the Township.

**Section 230. Lateral Charge.** A component of the Connection Fee for the installation, connection and use of the Sewer Lead or “Stub.”

**Section 231. May.** Is permissive.

**Section 232. MG/L.** Milligrams per liter.

**Section 233. Miscellaneous User Fee.** The amount charged to Users for miscellaneous services and related administrative costs associated with the System as the actual cost incurred by the Township plus administrative/enforcement costs.

**Section 234. Natural Outlet.** Any outlet into a Watercourse, pond, ditch, lake or other body of surface or ground water.

**Section 235. Normal Strength.** Generally, Sewage which when analyzed shows a daily average concentration of not more than 200 mg/l of BOD, nor more than 240 mg/l of Suspended Solids; nor more than 10 mg/l of phosphorous; nor more than 50 mg/l of fats, oils and grease; nor other substances which may solidify or become viscous between 32 degrees F and 150 degrees F; nor more than 40 mg/l of TKN; provided, however, that notwithstanding the foregoing, Normal Strength Sewage shall meet the City's requirements under the Grandville Contract.

**Section 236. Nuisance.** Without limitation, any condition where Sewage or the effluent from any Sewage Disposal Facility is exposed to the surface of the ground; or is permitted to drain on or to the surface of the ground or into any Natural Outlet.

**Section 237. pH.** The negative logarithm of the concentration of hydrogen ions in solution, in grams per liter. A measure of relative acidity (pH less than 7) or alkalinity (pH greater than 7) of the solution tested. A neutral solution has a pH of 7.

**Section 238. PPM.** Parts per million.

**Section 239. Person.** Any individual, firm, company, association, society, corporation or group, public or private.

**Section 240. Properly Shredded Garbage.** The wastes from the preparation, cooking and dispensing of foods that have been shredded or cut to such degree that all particles will be carried freely under the flow conditions normally prevailing in Public Sewers, with no particle greater than one-half inch in any dimension.

**Section 241. Public Sewer System or System.** The sanitary sewer collection and transmission system in the Township, which includes all publicly-owned Service Connections, mains, lift stations, odor control facilities and all appurtenances thereto.

**Section 242. Readiness to Serve Charge.** A component of the User Charge that represents a portion of (a) that User's proportionate share of the operation, maintenance and replacement costs of the System and (b) the benefit to that User derived from the availability of the System. The charge is based upon the allocation of REUs to the Premises.

**Section 243. Residential Equivalent Unit or Units.** A standard basis of measuring the relative quantity of Sewage, including the benefits derived from the disposal thereof, arising from the occupancy of a freestanding single-family residential dwelling (but such term shall not necessarily be related to actual use arising from any particular dwelling). A listing of the relative relationships between the various Users of the System, based on 16,500 gallons per quarter, is hereby determined by the Township and is set forth in Appendix III to this Ordinance. The assignment of Unit(s) to a particular User shall be determined from time to time by resolution of the Township Board, based upon the use to which the User's property is put. Each User shall be

assigned a minimum of one (1) Unit. A building containing multiple Users shall be assigned Units based on historical data from similar uses. The assignment of Unit(s) for any use not enumerated in Appendix III shall, in the sole discretion of the Township, be based upon the most similar use enumerated in Appendix III.

**Section 244. Sampling Manhole.** The structure installed on the Building Sewer or Service Connection pipeline to allow access for measurement and sampling of Sewage discharging from industrial and commercial establishments.

**Section 245. Septic Tank.** A watertight tank or receptacle used to receive Domestic Sewage and is intended to provide for the separation of substantial portions of the Suspended Solids in such Sewage and the partial decomposition by bacterial action on solids so separated.

**Section 246. Service Connection.** The portion of the Public Sewer System which extends either to or onto the parcel of land adjacent to the path of the Public Sewer System, and includes the sewer main, tee/wye, valve, the Sewer Lead, and any components associated with the Service Connection located in an easement granted to and accepted by the Township.

**Section 247. Service District.** All areas within the Township currently served by the System or capable of being served by the System, as shown on the map(s) attached hereto as Appendix I, primarily consisting of all residential-, commercial- and industrial-zoned land located within Sections 2-11 and 14-17 of the Township, which may be served in accordance with the Grandville Contract, and which are also located within the Township Master Plan's designated Growth Boundary. Only property located within these enumerated Sections and within the Growth Boundary may be served by the System.

**Section 248. Sewage Disposal Facilities.** Any Septic Tank, Subsurface Disposal System or other devices used in the disposal of Sewage and which are not part of the System.

**Section 249. Sewage Treatment Facility.** The publicly-owned physical plant and appurtenances designated to receive and treat the raw, untreated Sewage of the properties located in the Service District and served by the Public Sewer System, and owned by the City.

**Section 250. Sewage.** Any combination of the water-carried waste material from residences, business buildings, institutions and industrial establishments, including Industrial Wastes and Domestic Sewage.

**Section 251. Sewage Treatment Plant Connection Fee.** The fee charged by the City for each connection to the Public Sewer System based on either the number of Units for residential uses or meter size for commercial or industrial uses in accordance with the Grandville Contract.

**Section 252. Sewer Lead.** That portion of the Service Connection which connects to the sewer main located in the public right-of-way and extends therefrom to the property line.

**Section 253. Sewer Rates and Charges.** The Connection Fee (including the Trunkage Charge, Availability Fee, Lateral Charge and Sewage Treatment Plant Connection Fee), Inspection and Administration Fee, User Charge (including the Commodity Fee, Readiness to Serve Charge, and Debt Service Charge), User Surcharge, Miscellaneous User Fee and the civil penalty imposed pursuant to Section 306, and all interest and penalties thereon.

**Section 254. Shall.** Is mandatory.

**Section 255. Slug.** Any discharge of water, Sewage or Industrial Wastes which, in concentration of any given constituent or in quantity of flow, exceeds, for any period of time longer than fifteen (15) minutes, more than five (5) times the average twenty-four (24) hour concentration of flows during normal operation.

**Section 256. Special Assessment District.** All Special Assessment Districts determined at any time by the Township Board within the Service District for the provision of sanitary sewer service by the Public Sewer System.

**Section 257. Special Assessment Roll.** All Special Assessment District Rolls confirmed at any time for a Special Assessment District by the Township Board.

**Section 258. STED System.** Where an easement has been granted to and accepted by the Township, the publicly owned System Septic Tank and effluent gravity discharge pipe which provides the connection between the privately owned Building Sewer and the Public Sewer System. A sketch of a typical STED System is attached to this Ordinance as Appendix II-C.

**Section 259. STEP System.** Where an easement has been granted to and accepted by the Township, the publicly owned System Septic Tank, Effluent Pump, motor control panel and pressure discharge pipe, which provides the connection between the privately-owned Building Sewer and the Public Sewer System. A sketch of a typical STEP System is attached to this Ordinance as Appendix II-D.

**Section 260. Structure in which Sanitary Sewage Originates.** A building in which toilet, kitchen, laundry, bathing, or other facilities which generate Sewage are used or are available for use for household, commercial, industrial, or other purposes.

**Section 261. Storm Sewer or Storm Drain.** A sewer which carries storm or surface waters, or drainage, but excludes Sewage.

**Section 262. Subsurface Disposal System.** An arrangement for distribution of septic tank effluent beneath the ground surface (also referred to as a “drain field system,” “tile field” or “dry well” or a “soil absorption system”).

**Section 263. Superintendent.** The Superintendent of the Sewage Treatment Facility (or his or her designee) as appointed by the City.

**Section 264. Supervisor.** The Supervisor of the Township or his or her authorized representative.

**Section 265. S.S. or Suspended Solids.** Solids either floating or suspended in Sewage, or other liquids and which are removable by laboratory filtering and biologic processes.

**Section 266. System Septic Tank.** The Septic Tank specified for use in a STEP System.

**Section 267. Township.** The Charter Township of Jamestown, Ottawa County, Michigan, and/or its duly authorized agent or representative.

**Section 268. Township Engineer.** The person or entity designated by the Township Board as the engineer for the Public Sewer System.

**Section 269. Trunkage Charge.** The component of the Connection Fee to defray and pay for oversizing of sewer mains and trunk sewers, pumping facilities, and other System facilities and improvements to convey Sewage to the Sewage Treatment Facility.

**Section 270. Twenty-five Percent Rule or 25% Rule.** The 25% Rule means that the combined depth of oil and grease and other solids (floating and settled) in any chamber of a trap shall not be equal to or greater than 25 percent of the total operating depth of the trap. The operating depth of a trap is determined by measuring the internal depth from the water outlet invert elevation to the inside bottom of the trap.

**Section 271. U.S. EPA.** The United States Environmental Protection Agency.

**Section 272. User.** A recipient of services provided by the System including premises which are connected to and discharge Sewage into the System.

**Section 273. User Charge.** A charge, based on Units, charged to Users of the System. The charge represents (a) that User's proportionate share of the cost of Cost of the Operation and Maintenance (including Cost of Replacement) of the System; (b) the benefit to that User derived from the availability and use of the System; and (c) includes the Commodity Fee, Readiness to Serve Charge, and Debt Service Charge, if any.

**Section 274. User Class.** The classification of Users connected to sanitary sewers including but not limited to residential, industrial, commercial, institutional and governmental.

a. **Residential User.** A User of the System whose premises or buildings are used primarily as a domicile for one or more persons including Dwelling Units such as detached, semi-detached and row houses, mobile homes, apartments or permanent multi-family dwellings (transit lodging is not including, it is considered a Commercial User).

b. **Industrial User.** Shall mean a User of the System which discharges Industrial Wastes as distinct from its employees Domestic Sewage.

c. **Commercial User.** Shall mean an establishment listed in the Office of the Management and Budget's "Standard Industrial Classification Manual" (SICM) (or a successor publication), involved in a commercial enterprise, business or service which, based on a determination by the Township discharges primarily segregated Domestic Sewage and which is not a Residential User or an Industrial User.

d. **Institutional User.** Shall mean any establishment listed in the SICM involved in a social, charitable, religious or educational function which based on the determination by the Township discharges primarily segregated Domestic Sewage.

e. **Governmental User.** Shall mean any federal, state or local government User of the System.

**Section 275. User Surcharge.** A charge imposed on a User of the System for discharges of Sewage that are in excess of Normal Strength Sewage.

**Section 276. Watercourse.** A channel in which a flow of water occurs, either continuously or intermittently.

### **ARTICLE III USE OF PUBLIC SEWER SYSTEM REQUIRED**

**Section 301. Discharge of Sewage.** No Person shall discharge to any Natural Outlet within the Service District any Sewage or other polluted waters except where suitable treatment has been provided in accordance with standards established by EGLE, U.S. EPA and this Ordinance.

**Section 302. Sewage Disposal Facilities.** Except as provided in this Ordinance, no Person shall construct or maintain in the Service District any Sewage Disposal Facilities.

**Section 303. Mandatory Connection of Properties in Special Assessment District.** All owners of Structures in which Sanitary Sewage Originates, now situated or hereafter constructed within a Special Assessment District, are hereby required at their expense to install suitable plumbing fixtures and connect such facilities directly with the Available Public Sanitary Sewer System in accordance with the provisions of this Ordinance. The Township may require any such owners, pursuant to the authority conferred upon it by law or ordinance, to make such installations or connections which must have the approval (during and after construction) of the Inspector.

**Section 304. Connection of Existing Improved Properties in Service District Outside Special Assessment District.** Owners of all presently situated Structures in which Sanitary Sewage Originates, which are located in the Service District and which are currently served by private Sewage Disposal Facilities, shall not be required to connect to the Available Public Sanitary Sewer System until such time as:

- a. the existing private Sewage Disposal Facilities fail (as determined by the Health Department) and the Health Department will not issue a permit for new private Sewage Disposal Facilities for the premises, or
- b. connection of all improved properties within the area in which said premises are located is declared a necessity by the Township for the public health and welfare.

Upon the occurrence of any such event connection shall be made to the Public Sewer System in accordance with Section 303 and Section 305. In the alternative, an owner of property subject to this Section 304, may connect to the Public Sewer System at any time in compliance with the terms of this Ordinance.

**Section 305. Connection Deadline.** As a matter of public health, all connections to the Public Sewer System required hereunder, shall be completed no later than twelve (12) months after the last to occur of the date of official notice by the Township to make said connections or the modification of a structure so as to become a Structure in which Sanitary Sewage Originates. Newly constructed structures required to connect shall be connected prior to occupancy thereof.

Persons who fail to complete a required connection to the Public Sewer System within such twelve (12) month period shall be liable for a civil penalty equal in amount to the User Charges and Debt Service Charges that would have accrued and been payable had the connection been made as required.

**Section 306. Enforcement in the Event of a Failure to Connect.** In the event a required connection to the Public Sewer System is not made within the time provided by Section 305, the Township shall require the connection to be made immediately after notice given by first class or certified mail or by posting on the property. The notice shall give the approximate location of the Available Public Sanitary Sewer System and shall advise the owner of the affected property of the requirement and enforcement provisions provided by Township ordinance and state law. In the event the required connection is not made within 90 days after the date of mailing or posting of the written notice, the Township may bring an action in the manner provided by law in a court of competent jurisdiction for a mandatory injunction or court order to compel the property owner to immediately connect the affected property to the Available Public Sanitary Sewer System.

**Section 307. Extensions of Public Sewer System to Service New Developments.**

a. The owner of a premises located within the Service District but not served by an Available Public Sanitary Sewer System may elect to extend the Public Sewer System and connect his premises thereto, subject to the conditions for sewer extensions set forth in Section 309.

b. The owner (or developer) of lands in the Township proposed for development (whether by site condominium, subdivision, land division or otherwise) for which land use approval is received after the effective date of this Ordinance, shall be required to extend the Public Sewer System and connect the premises so developed to the Public Sewer System subject to the conditions for sewer extensions set forth in Section 309 if the distance measured in feet from the nearest edge of the proposed development to the nearest point of the Public Sewer System when divided by the number of Units proposed for the development equals fifty feet or less. This subsection 307.b. shall not apply to lands improved by one single family residence located adjacent to the then existing terminus of the Public Sewer System.

**Section 308. Connection of Premises Located Outside the Service District.** Premises located outside the Service District shall be permitted to connect to the Public Sewer System only upon the consent of the Township Board and subject to the provisions of the Grandville Contract. The consent of the Township Board shall be granted or denied by the Township Board in the exercise of its reasonable discretion and shall be based upon the continued availability of capacity in the Public Sewer System for premises located within the Service District, the provisions of the Grandville Contract, and may be based upon such other considerations deemed appropriate by the Township Board and consistent with this Ordinance, including, but not limited to, the terms of the Contract, if applicable. To the extent an extension of the Public Sewer System is required, the conditions set forth in Section 309 shall apply. In its discretion, the Township Board may require the person requesting the connection of premises located outside the Service District to provide, at the sole expense of said person, an engineering report by a consulting engineer acceptable to the Township addressing the cost and feasibility of the proposed sewer service (and any sewer extension necessitated thereby) in the context of the foregoing considerations.



**Section 309. Conditions for Extension of Public Sewer System by Property Owner.**

If connection to the Public Sewer System is required by Section 307.b. of this Ordinance, but there is no Available Public Sanitary Sewer System adjacent to the premises, or if a property owner elects to extend the Public Sewer, such extension shall be in accordance with the following requirements, unless modified by the terms of a written agreement between the Township and the property owner pursuant to Section 310:

a. The sewer main shall be extended to the premises in a public right of way, or in an easement owned by the public to the premises in question. If the sewer is to be extended for the purpose of serving a new development, including but not limited to a site condominium, subdivision, or division of land which involves the installation of a new public or private road, the sewer main shall be extended throughout such new road so that the sewer abuts all units or lots within the development, within an easement dedicated to the public if not located in a public street right of way.

b. If a sewer main is extended to a premises, the main shall be installed across the entire frontage of the premises served, to the border of the adjacent premises and extended through the premises served and to the adjoining premises where required by the Township Engineer. For developments for which a new public or private road is constructed, the sewer main shall be extended across the entire frontage of the development on the existing adjacent public or private road, in addition to being extended within the new road to all lots or units within the development. All sewer main extensions shall be located within an easement dedicated to the public, if not located in a public street right of way.

c. The sewer main shall be constructed in accordance with the Township's then-current Standard Specifications for Construction (or its successor document).

d. The design, planning and construction of the sewer main and related facilities shall comply with all State and County requirements and approval procedures.

e. Upon completion of the sewer main, verification by the Inspector that it has been properly constructed, and proof that all contractors have been paid for the cost thereof (including lien waivers if requested), the sewer main shall be dedicated to the Township, without cost to the Township. Upon acceptance of dedication, the Township shall thereafter be responsible for maintenance of the sewer main. The Township shall be assigned, or be a third party beneficiary of, all construction contracts and material and equipment warranties.

f. The person responsible for installing the sewer shall reimburse the Township for the cost to review plans and specifications of the sewer extension including, but not limited to, costs of the Township Engineer to review said plans and specifications, and the cost of acquisition of right-of-way, if necessary, including attorney fees, appraisal fees, cost of land title research and all other expenses of any condemnation proceedings. At the election of the Township, the person responsible for installing the sewer shall pay an amount to the Township, in advance, at least equal to the estimated fees for such review and acquisition. Any excess not required to complete the improvements shall be refunded to the responsible party; any shortfall shall be paid before connection of any premises is permitted.

g. The entire cost of installation of the sewer main, including but not limited to engineering, construction, permits and restoration shall be paid by the owner or owners of the premises to whom sewer is being extended.

h. In addition to the extension of a sewer main as required, the owner of premises to be connected to the System shall reimburse the Township for the cost of making improvements to downstream facilities, which are necessary as a result of the additional connections proposed to be made by the owner of the premises or by a development which will be provided with public sewer, including but not limited to increasing the size of sewer mains to provide sufficient capacity, increase in the capacity of lift stations, and increase in treatment capacity of the Wastewater Treatment Plant. In such a situation, the responsible party and the Township shall enter into an agreement whereby the responsible party pays to the Township, in advance, an amount equal to at least the estimated cost of making such improvements. Any excess not required to complete the improvements shall be refunded to the responsible party; any shortfall shall be paid before connection of any premises is permitted.

i. In its discretion, the Township Board may require the person requesting the extension or required to construct an extension to provide at the sole expense of said person an engineering report by a consulting engineer acceptable to the Township addressing the cost and feasibility of the proposed extension in the context of the foregoing conditions.

j. No building shall be connected to such extension until the extension has been accepted by the Township and all necessary documents for conveyance of such extension have been executed and delivered to the Township.

**Section 310. Sewer Extension Agreements.** The Township shall have the authority to negotiate agreements for sewer extensions with landowners, developers and other municipalities, which agreements may take into consideration issues of demand, benefit, capacity, necessity, timing and funding and may provide for construction advances, prepayment of rates and charges, pay back arrangements of up to 10 years and similar matters.

#### **ARTICLE IV PRIVATE SEWAGE DISPOSAL**

**Section 401. Private Sewage Disposal Facilities.** If a Public Sewer System is not available to a parcel of land located in the Service District in accordance with the provisions of Article III, the Building Sewer shall be connected to private Sewage Disposal Facilities constructed in compliance with requirements of the Health Department and EGLE.

**Section 402. Operation and Maintenance.** The owner shall operate and maintain the private Sewage Disposal Facilities in a sanitary manner at all times, at no expense to the Township.

**Section 403. Governmental Requirements.** No statement contained in this Article shall be construed to interfere with any additional requirements that may be imposed by the Township, the Health Department, EGLE or any other governmental agency with jurisdiction over the Service District.

**Section 404. Connection to Public Sewer System; Abandonment.** At such time as the Public Sewer System becomes available to a parcel served by private Sewage Disposal Facilities,

as provided in accordance with Article III, the Building Sewer shall be connected to the Public Sewer System in compliance with this Ordinance and the private Sewage Disposal Facilities shall be abandoned for sanitary use in the manner required by the Health Department.

## **ARTICLE V BUILDING SEWERS AND CONNECTIONS**

**Section 501. Permit Requirement.** No unauthorized person shall uncover, make any connections with or opening into, use, alter, or disturb any portion of the Public Sewer System without first obtaining a written permit from the Township in accordance with Section 502.

**Section 502. Permit Application.** A connection to the Public Sewer System shall be made only by an authorized contractor or plumber upon written authorization and a Service Connection permit issued by the Township. Prior to said connection, the property owner or his agent shall submit a permit application to the Township. This permit application shall be on a form furnished by the Township and shall be accompanied by payment of the applicable Connection Fee determined in accordance with Section 702, any civil penalty which has accrued pursuant to Section 306 above and the Inspection and Administration Fee, the plans and specifications of all plumbing construction within the premises (when requested), and all other information required by the Township.

**Section 503. Approval of Application.** The approval of a Service Connection permit application shall be subject to:

- a. compliance with all terms of this Ordinance, including, without limitation, Section 502, above, and the rules and regulations of the Health Department and EGLE,
- b. the availability of capacity in the System, including Compatible Pollutant capacity,
- c. compliance of the plans and specifications for connection with the Township's then-current Standard Specifications for Construction (or its successor document), as adopted by the Township Board from time to time; and
- d. a separate and independent Building Sewer and Service Connection shall be provided for every building; except where one building stands at the rear of another on an interior lot and no private sewer is available or can be constructed to the rear through an adjoining alley, court, yard, or driveway, the Building Sewer from the front building may be extended to the rear building and the whole considered as one Building Sewer with a single Service Connection. Other exceptions will be allowed only by special permission granted by the Township.

**Section 504. Excavations, Pipe Laying and Backfill.** All excavations, pipe laying and backfill required for the installation of Building Sewers and Service Connections shall be done to conform to the Township's Standard Specifications for Construction. No backfill shall be placed until the work has been inspected and approved by the Inspector.

**Section 505. Connection of Building Sewer.** The connection of the Building Sewer to the Public Sewer System shall be made at the Service Connection.

**Section 506. Connection of Certain Drains is Prohibited.** No Person shall make connection of roof downspouts, exterior footing or foundation drains, areaway drains, storm drains, or other points of entry of surface runoff or groundwater to a Building Sewer or Building Drain which in turn is connected directly or indirectly to the Public Sewer System.

**Section 507. Public Safety Requirements; Restoration.** All excavations for Building Sewer installation and connection to the Public Sewer System shall be adequately guarded with barricades and lights so as to protect the public from hazard. Streets, sidewalks, parkways and other public property disturbed in the course of the work shall be restored at the cost of the property owner in a manner satisfactory to the Township, the County Road Commission and all other governmental entities having jurisdiction.

**Section 508. Cost of Installation of Building Sewer and Connection to Public Sewer; Indemnification.** All costs and expenses incidental to the installation of the Building Sewer and the connection thereof to the Public Sewer System shall be borne by the owner of the property being connected. No such work shall commence before such owner obtains any necessary permission to work in the public right of way from the County Road Commission. Said owner shall indemnify the Township from all loss or damage that may directly or indirectly be caused by the installation and connection of the Building Sewer to the Public Sewer System.

**Section 509. Inspection.** A Service Connection permittee shall notify the Inspector (and provide not less than 48 hours prior notice) when the Building Sewer and Service Connection are ready for inspection. The excavation shall be left open until inspection is complete. If the Inspector determines that the Building Sewer and Service Connection have been constructed and installed in accordance with the requirements of this Ordinance, the Building Sewer shall then be connected with the Service Connection under the observation of the Inspector. The inspection shall include the installation of all required components of the Service Connection, including without limitation, wiring, conduit, sealants, riser, discharge lines and related necessary appurtenances. The inspection required by this Section shall include the abandonment of the private Sewage Disposal Facilities in the manner required by the Health Department.

**Section 510. Township's Responsibility for Repairs, Operation and Maintenance.** The cost of all repairs, operation, maintenance and replacement of the Public Sewer System, as well as each Service Connection which is a Gravity System for which the property owner has granted an easement to, and which easement has been accepted by the Township, shall be borne by the Township as part of the Township's budgeted annual expense of the System, subject to the right of the Township to impose a Miscellaneous User Fee in accordance with Section 705, below.

**Section 511. Property Owner's Responsibility for Repairs, Operation and Maintenance.** The cost of all repairs, operation, maintenance and replacements of existing Building Sewers and their connection to Public Sewer Systems shall be borne by the property owner. If the property owner has not granted an easement to the Township (or the Township has not accepted such an easement) to maintain a Service Connection which is a Grinder Pump System, then the cost of all repairs, operation, maintenance and replacement of the Service Connection shall also be borne by the property owner.

**ARTICLE VI  
USE OF THE PUBLIC SEWER SYSTEM**

**Section 601. Prohibited Discharge of Storm Water.** No Person shall discharge or cause to be discharged any storm water, surface water, ground water, water from footing drains, roof runoff, subsurface drainage, unpolluted cooling water or unpolluted industrial process waters to the Public Sewer System. Any premise connected to a Storm Sewer shall comply with county, state and federal requirements as well as those of the Township.

**Section 602. Permissible Discharge of Storm Water.** Unpolluted water, storm water and all other unpolluted drain water shall be discharged to the ground surface, to a Natural Outlet or to a Storm Sewer or Storm Drain in accordance with applicable state and federal regulations.

**Section 603. Prohibited Discharges to Public Sewer System.**

a. No User shall contribute or cause to be contributed, directly or indirectly, any pollutant or wastewater which will interfere with the operation or performance of the System or the Sewage Treatment Facility. These general prohibitions apply to all such Users whether or not the User is subject to the National Categorical Pretreatment Standards of any other national, state or local Pretreatment Standards or requirements. A User may not contribute the following substances to the System or the Sewage Treatment Facility:

(1) Any liquids, solids or gases which by reason of their nature or quantity are, or may be, sufficient either alone or by interaction with other substances to cause fire or explosion or be injurious in any other way to the System or the Sewage Treatment Facility or to the operation of the System or the Sewer Treatment Facility. Prohibited materials include, but are not limited to, gasoline, kerosene, naphtha, benzene, toluene, xylene, ethers, alcohols, ketones, aldehydes, peroxides, chlorates, perchlorates, bromates, carbides, hydrides and sulfides.

(2) Solid or viscous substances which may cause obstruction to the flow in a sewer or other interference with the operation of the Sewage Treatment Facility such as, but not limited to: grease, garbage that is not Properly Shredded Garbage, animal guts or tissues, paunch manure, bones, hair, hides or fleshings, entrails, whole blood, feathers, ashes, cinders, sand, spent lime, stone or marble dust, metal, glass, straw, shavings, grass clippings, rags, spent grains, spent hops, waste paper, so-called “flushable wipes” or similar products, wood, plastics, gas, tar, asphalt residues, residues from refining, or processing of fuel or lubricating oil, mud, or glass grinding or polishing wastes.

(3) Any Sewage having a pH less than 5.5 or greater than 9.5, or Sewage having any other corrosive property capable of causing damage or hazard to structures, equipment, or personnel of the System or the Sewage Treatment Facility.

(4) Any Sewage containing toxic pollutants in sufficient quantity, either singly or by interaction with other pollutants, to injure or interfere with any wastewater treatment process, constitute a hazard to humans or animals, create a toxic effect in the receiving waters of the Sewage Treatment Facility, or exceed the limitation set forth in a categorical pretreatment standard.

(5) Any noxious or malodorous liquids, gases, or solids which either singly or by interaction with other wastes are sufficient to create a public nuisance or hazard or to prevent entry into the sewers for maintenance and repair.

(6) Any substance which may cause the System's or Sewage Treatment Facility's effluent or any other product thereof such as residues, sledges, or scums, to be unsuitable for reclamation and reuse or to interfere with the reclamation process.

(7) Any substance which will cause the Sewage Treatment Facility to violate its Discharge Permit or the receiving water quality standards.

(8) Any Sewage with objectionable color not removed in the treatment process, such as, but not limited to, dye wastes and vegetable tanning solutions.

(9) Any Sewage having a temperature which will inhibit biological activity in the System or the Sewage Treatment Facility resulting in interference, but in no case Sewage with a temperature at the introduction into the System or Sewage Treatment Facility which exceeds 40°C (140°F).

(10) Any pollutants, including oxygen demanding pollutants (BOD, etc.) released at a flow rate and/or pollutant concentration which will cause interference to the System or Sewage Treatment Facility.

(11) Any Sewage containing any radioactive wastes or isotopes of such half-life or concentration as may exceed limits established by the Township in compliance with applicable state or federal regulations.

(12) Any Sewage which causes a hazard to human life or creates a public Nuisance.

(13) Any sludge, precipitate or congealed substances resulting from an industrial or commercial process, or resulting from the pretreatment of wastewater or air pollutants.

(14) Any contaminant in excess of those contained in an order of determination issued by the Superintendent.

Upon the promulgation of the national categorical pretreatment standards for a particular industry subcategory, the pretreatment standard if more stringent than limitations imposed under this Ordinance shall immediately supersede the limitations imposed under this Ordinance and shall be considered part of this Ordinance and the Township shall notify all affected Users of the applicable reporting requirements.

**Section 604. Discharge Permit Limitations.** No Person shall discharge or cause to be discharged into the System any Sewage which would cause effluent from the Sewage Treatment Facility to exceed discharge limits established in the Discharge Permit issued for operation of the System.

**Section 605. Remedies; Pre-Treatment.** If any Sewage is discharged, or is proposed to be discharged to the Public Sewer System, and such Sewage contains the substances or possesses the characteristics enumerated in Section 603 or Section 604, and which in the judgment of the Township may have a harmful effect upon the System or Sewage Treatment Facility, or receiving waters, or which otherwise create a hazard to life or constitute a public Nuisance, the Township may take the actions necessary to:

- a. Effect a cease and desist of the discharge of the Sewage to the Public Sewer System.
- b. Reject the Sewage.
- c. Require pre-treatment of the Sewage to an acceptable condition prior to discharge to the Public Sewer System.
- d. Require control over the quantities and rates of discharge.
- e. Require payment of a User Surcharge to cover the added cost of handling and treating the Sewage pursuant to Section 703 and Section 704 hereof.

Any Industrial User who discharges Sewage to the System shall pretreat or limit the discharge to conform to standards set forth in the Code of Federal Regulations 40 CFR 403 (Pretreatment) or any applicable more stringent state or local rules, regulations or standards.

If the Township permits the pre-treatment or equalization of Sewage flows, the design and installation of the pre-treatment plants and equipment shall be subject to the review and approval of the Township, the City, the County, the Health Department, EGLE, and shall also be subject to the requirements of all applicable codes, ordinances, regulations and laws. No construction of pre-treatment or equalization facilities shall take place until all necessary approvals are obtained in writing, and copies of said approvals are forwarded to the Township.

**Section 606. Maintenance of Pre-Treatment Facilities.** Where preliminary treatment or flow equalizing facilities are provided for any Sewage, said facilities shall be maintained continuously in satisfactory and effective operation by the owner at no expense to the Township.

**Section 607. Special Arrangements; Surcharge.** No statement contained in this Article shall be construed as preventing any special agreement or arrangement between the Township and any User whereby Sewage of unusual strength or character may be accepted by the Township for treatment, subject to the payment of a User Surcharge by the User and provided such Sewage will not damage the System, the Sewage Treatment Facility or the receiving water.

**Section 608. Grease, Oil and Sand Interceptors.**

- a. Grease, oil, and sand interceptors shall be installed, operated, maintained, repaired and replaced by the individual User and at no cost to the other Users of the System when determined by the Township to be necessary for the proper handling of Sewage containing ingredients described in Section 603 of this Article. In addition to the requirements set forth herein, Grease, oil, and sand interceptors shall be constructed, operated and maintained in accordance with the Township's then-current Standard Specifications for Construction

b. All establishments where food is manufactured, sold or prepared, except for small areas designated as employee break areas or the equivalent, discharging wastewater containing fats, oils, and grease (FOG) to the Sewer System shall install, operate, and maintain a tank of a size and material and so designed as to be capable of removing grease and oily wastes from the Sewage (hereinafter called "Grease Trap") necessary to achieve and maintain compliance with the Wyoming Sewage Treatment Agreement.

c. Unless otherwise authorized by the Engineer, all Grease Traps shall be of the outdoor, inline variety. With special authorization by the Engineer, Grease Traps of the indoor, under-counter, stand-alone variety may be allowed. In this case, maintenance of indoor Grease Traps shall be performed at frequencies necessary to protect the capacity of the Sewer System against accumulation of grease and oils, as required by the "25% Rule" as defined in this Ordinance. Under no condition shall an indoor Grease Trap be cleaned at intervals less than once every 14 days.

d. Grease Traps and oil and sand interceptors shall be provided when they are necessary for the proper handling of liquid wastes containing grease in excessive amounts or any flammable wastes, sand or other harmful ingredients. Such traps and interceptors shall not be required for Dwelling Units. All interceptors shall be of a type and capacity approved by the Engineer and shall be located so as to be readily accessible for cleaning and inspection.

e. Grease Traps and oil interceptors shall be constructed of impervious materials capable of withstanding abrupt and extreme changes in temperature. They shall be of substantial construction, watertight and equipped with easily removable covers which, when bolted in place, shall be gastight and watertight.

f. Where installed, all Grease Traps and oil and sand interceptors shall be cleaned and maintained by the owner and shall be operated continuously in an efficient manner whenever the facility is in operation. The Township shall have the right to inspect maintenance and disposal records related to the operation of Grease Traps and oil and sand interceptors.

g. The Customer shall be responsible for the proper removal and legal disposal of the Grease Trap waste. All waste removed from each Grease Trap must be disposed of at a facility permitted to receive such waste. No Grease Trap pumpage may be discharged to the Sewer System. Maintenance shall include the complete removal of all contents, including floatable materials, wastewater, sludges and solids and jet flushing to remove measurable build-up on tank walls. Top skimming of outdoor Grease Traps, decanting or back flushing of the Grease Trap or its wastes for the purpose of reducing the volume to be hauled is prohibited.

h. There shall be ample room and reasonable access to interceptors to allow accurate sampling and preparation of samples for transport and analysis.

i. Notwithstanding other provisions of this Ordinance to the contrary, if a Grease Trap or interceptor is required to comply with the current plumbing codes adopted by the Township, the Grease Trap or interceptor shall meet the following minimum requirements: a 1,000 gallon, 3 compartment, H<sub>2</sub>O loading, concrete, water proof, leak proof structure with 3 access and testing ports. The Engineer may authorize, in writing, an exception to the foregoing minimum requirements, and the Engineer shall otherwise make the final determination and approval of a



Grease Trap's size. If additional pretreatment and/or maintenance is required to meet the provisions in this Section, the Engineer may require that the establishment in existence prior to the effective date of this Section upgrade to the requirements provided.

j. Maintenance of an outdoor Grease Trap shall be performed at frequencies necessary to protect the capacity of the Sewer System against accumulation of grease and oils, as required by the 25% Rule and at intervals no less than once every 90 days.

k. Use of any bacteriological, chemical, or enzymatic addition for the purpose of maintaining a Grease Trap is prohibited unless written approval is obtained from the Engineer.

l. The Customer shall be responsible for maintaining records and/or manifests as to the dates of service, quantity and waste hauler name at the Customer's location for a period of three years, which records shall be subject to review by the Township without prior notification.

m. Should any user fail to properly clean and maintain a Grease Trap or oil and sand interceptor as required herein, the Township, at its option may contract for appropriate cleaning and maintenance by a licensed contractor, the cost of which shall be collectable by the Township from the Customer at a charge of actual cost plus 100 percent as a Miscellaneous Customer Fee.

**Section 609. Sampling Manhole.** When required by the Township and/or the City, the owner(s) of any property serviced by a Building Sewer carrying Industrial Wastes shall install a suitable Sampling Manhole upstream from the connection to the Public Sewer System. The purpose of this Sampling Manhole shall be to enable observation, sampling, and measurements of the Industrial Wastes. The Sampling Manhole shall be at the property line or in a location approved by the Township, shall be easily accessible, and shall be constructed in accordance with plans and specifications approved by the Township and the Township Engineer. Installation of the Sampling Manhole, sampling equipment and other appurtenances required by the Township and/or the City shall be at the expense of the property owner. The owner shall operate, maintain, repair and replace the Sampling Manhole and appurtenances in a safe, accessible and operable manner at all times at his or her expense.

**Section 610. Testing of Industrial Wastes.** All measurements, tests, and analyses of characteristics of Industrial Wastes shall be conducted on samples obtained at the Sampling Manhole. Where no specific control manhole has been constructed, the Sampling Manhole shall be considered to be in the nearest downstream manhole in the Public Sewer System to the point at which the Building Sewer is connected. Costs for said testing may, at the discretion of the Township, be charged to the User discharging the Industrial Wastes as a Miscellaneous User Fee.

**Section 611. Test Standards.** All measurements, tests, and analyses of Sewage characteristics described in this Article shall be determined in accordance with the current "Standard Methods for the Examination of Water and Sewage," as published by the American Public Health Association. Sampling shall be conducted by customarily accepted methods to reflect the effect of constituents upon the System and the Sewage Treatment Facility and to determine the existence of hazards of life and property. The particular analyses involved will determine whether a 24 hour composite of all outfalls of a premise is appropriate or whether grab samples should be taken.

**Section 612. Industrial Users; Permits; Information Required; Records.**

a. **Industrial Users.** Industrial users discharging to the System shall provide necessary wastewater treatment as required to comply with this ordinance and shall achieve compliance with all pretreatment standards within the time limitations as specified by the national pretreatment regulations and as required by the Township and the City. Any facilities required to pretreat wastewater to a level acceptable to the township shall be provided, operated, and maintained at the user's expense. Detailed plans showing the pretreatment facilities and operating procedures shall be submitted to the Superintendent for review, and shall be approved by the Superintendent before construction of the facility. The review of such plans and operating procedures shall in no way relieve the user from the responsibility of modifying the facility as necessary to produce an effluent acceptable to the Township and/or the City under the provisions of this ordinance. Any subsequent changes in the pretreatment facilities or method of operation shall be reported to and be acceptable to the Superintendent prior to the user's initiation of the changes.

The Township (or Grandville on behalf of the Township) shall annually publish in the local newspaper having the largest township circulation a list of the users with significant violations of any National Categorical Pretreatment Standards during the 12 previous months. The list shall also summarize any enforcement actions taken against the user(s) during the same 12 months.

All records relating to compliance with pretreatment standards shall be made available to officials of the EPA or EGLE upon request.

b. **Information Required.** All non-domestic users proposing to connect to or to contribute to the sewage works shall submit information on their processes and wastewater to the Township before connecting to or contributing to the sewage works. All existing industrial users connected to or contributing to the sewage works shall submit this information upon request of the Superintendent. The information submitted must be sufficient for the township to determine the impact of the user's discharge on the sewage works and the need for pretreatment. The user shall submit, in units and terms appropriate for evaluation, the following information:

- (1) Name, address and location (if different from the address).
- (2) SIC number.
- (3) Wastewater constituents and characteristics listed in an order of determination issued by the Superintendent and/or as established by a reliable analytical laboratory determination.
- (4) Time and duration of contribution.
- (5) Average daily and instantaneous peak wastewater flow rates, including daily, monthly and seasonal variations, if any.
- (6) Industries identified as significant industries or subject to the National Categorical Pretreatment Standards or Alternative Discharge Limits or those required by the Township must submit site plans, floor plans, mechanical and plumbing

plans and details to show all sewers, sewer connections, inspection manholes, sampling chambers, and appurtenances by the size, location and elevation.

(7) Description of activities, facilities and plant processes on the premises including all materials which are or could be discharged.

(8) Where known, the nature and concentration of any pollutants in the discharge which are limited by any township, state, or federal pretreatment standards, and a statement regarding whether or not the pretreatment standards are being met on a consistent basis and if not, whether additional pretreatment is required by the industrial user to meet applicable pretreatment standards.

(9) If additional pretreatment will be required to meet the pretreatment standards, the shortest schedule by which the user will provide such additional pretreatment. The completion date in this schedule shall not be later than the compliance date established for the applicable pretreatment standard. The following conditions shall apply to this schedule:

(a) The schedule shall contain increments of progress in the form of dates for the commencement and completion of major events leading to the construction and operation of additional pretreatment required for the user to meet the applicable pretreatment standards, including, but not limited to, dates related to hiring an engineer, completing preliminary plans, completing final plans, executing contracts for major components, commencing construction, completing construction, and all other acts necessary to achieve compliance with this ordinance.

(b) No increment referred to in Paragraph (a) shall exceed two months.

(c) Not later than 15 days following each date in the schedule and the final date for compliance, the user shall submit a progress report to the Superintendent including, as a minimum, whether or not it complied with the increment of progress to be met on such date and, if not, the date on which it expects to comply with this increment of progress, the reason for delay, and the steps being taken by the user to return the construction to the schedule established. In no event shall more than three months elapse between such progress reports to the Superintendent.

(10) Each product produced by type, amount, process or processes, and rate of production.

(11) Type and amount of raw materials processed, average and maximum per day.

(12) Number and type of employees, hours of operation of plant and proposed or actual hours of operation of pretreatment system.

(13) Any other information as may be deemed by the Township to be necessary to evaluate the impact of the discharge on the sewage works.

c. **Timing.** Within six months after the promulgation or revision of a pretreatment standard, all affected users shall submit to the Township the information required by Section 612.b.(8) and (9).

d. **Additional Charges.** Wastewater discharges shall be expressly subject to all provisions of this ordinance and all other applicable regulations, charges and fees established by the Township. The Township may:

(1) Set unit charges, surcharges, or a schedule of other charges and fees for the wastewater to be discharged to the sewage works.

(2) Limit the average and maximum/minimum wastewater constituents and characteristics.

(3) Limit the average and maximum rate and time of discharge or establish requirements for flow regulations and equalization.

(4) Require the installation and maintenance of inspection and sampling facilities.

(5) Establish specifications for monitoring programs, which may include sampling locations, frequency of sampling, number, types and standards for tests and reporting schedule.

(6) Establish compliance schedules.

(7) Require submission of technical reports or discharge reports.

(8) Require the maintaining, retaining and furnishing of plant records relating to wastewater discharge, as specified by the Township; the Township shall have access to and the right to copy these records.

(9) Require notification of the Township for any new introduction of wastewater constituents or any substantial change in the volume or character of the wastewater constituents being introduced into the wastewater treatment system.

(10) Require notification of slug discharges.

(11) Require other conditions as deemed appropriate by the Township to ensure compliance with this ordinance.

e. **Reporting.** Within 90 days following the date for final compliance with applicable pretreatment standards or, in the case of a new source, following commencement of the introduction of wastewater into the sewage works, any user subject to pretreatment standards and requirements shall submit to the Superintendent a report indicating the nature and concentration of all pollutants in the discharge from the regulated process which are limited by pretreatment

standards and requirements and the average and maximum daily flow for these process units in the user's facility which are limited by such pretreatment standards or requirements. The report shall state whether the applicable pretreatment standards or requirements are being met on a consistent basis and, if not, what additional pretreatment is necessary to bring the user into compliance with the applicable pretreatment standards or requirements. This statement shall be signed by an authorized representative of the industrial user. Any industrial user or new source discharging into the sewage works, which is subject to a pretreatment standard shall submit to the Superintendent semiannually, unless required more frequently in pretreatment standard or by the Superintendent, a report indicating the nature and concentration of pollutants in the effluent which are limited by the pretreatment standard. In addition, this report shall include a record of all daily flows which, during the reporting period, exceeded the average daily flow previously reported pursuant to Section 612.b. At the discretion of the Superintendent, and after consideration of such factors as local high or low flow rates, holidays, budget cycles, etc., the manager may alter the months during which the above reports are to be submitted. The Superintendent may also impose mass limitations on users which are using dilution to meet applicable pretreatment standards or requirements, or in other cases in which the imposition of mass limitations is appropriate. In such cases, the report required by this paragraph shall also indicate the mass of pollutants regulated by pretreatment standards in the effluent of the user.

f. **Monitoring Facilities.** The Township may require to be provided and operated at the User's expense, monitoring facilities to allow inspection, sampling, and flow measurement of the Building Sewer and/or internal drainage systems. The monitoring facility will normally be situated on the User's premises, but the Township may, when such a location would be impractical or cause undue hardship on the user, allow the facility to be constructed in the public street or sidewalk area and located so that it will not be obstructed by landscaping or parked vehicles. There shall be ample room in or near such sampling manhole or facility to allow accurate sampling and preparation of samples for analysis. The facility, sampling, and measuring equipment shall be maintained at all times in a safe and proper operating condition at the expense of the user. Whether constructed on public or private property, the sampling and monitoring facilities shall be provided in accordance with plans and specifications submitted to and approved by the Township. The facilities shall be designed and constructed in accordance with all township building codes and all other applicable laws, rules, and regulations. Construction shall be completed within 90 days following written notification by the Township.

g. **Meters.** All industrial sewer customers shall either have approved meters on all water sources that ultimately discharge into the Public Sewer System or shall meter the liquid wastes at the point of discharge into the Public Sewer System. Meters shall perform according to manufacturer's standards and specifications and each customer shall annually test the meter, at no cost to the Township or the City, and provide the results of such test to the Township and/or the City.

h. **Public Information.** Information and data on a User obtained from reports, questionnaires, permit applications, permits and monitoring programs agencies and from inspections shall be available to the public or other governmental agency without restriction unless the User specifically requests and is able to demonstrate to the satisfaction of the Township that the release of such information would divulge information, processes or methods of production entitled to protection as trade secrets of the User and that such information is exempt from disclosure under the Michigan Freedom of Information Act.

When requested by the person furnishing a report, the portion of a report which might disclose trade secrets or secret processes shall not, to the extent permitted by the Michigan Freedom of Information Act, be made available for inspection by the public but shall be made available upon written request to governmental agencies for uses related to this ordinance, the NPDES permit, or the pretreatment programs; provided, however, that such portions of a report shall be available for use by the state or any state agency in judicial review or enforcement proceedings involving the person furnishing the report. Wastewater constituents and characteristics will not be recognized as confidential information.

**Section 613. Maintenance of Records.** All Users subject to this ordinance shall retain and preserve for no less than three years, any records (including, but not limited to, grease trap and oil/sand separator cleaning and repair records, and meter testing records), books, documents, memoranda, reports, correspondence and any and all summaries thereof, relating to monitoring, sampling and chemical analyses made by or on behalf of a discharger in connection with its discharge. All records which pertain to matters which are the subject of any enforcement or litigation activities brought by the Superintendent pursuant hereto shall be retained and preserved by the User until all enforcement activities have concluded and all periods of limitation with respect to any and all appeals have expired.

## **ARTICLE VII SEWER RATES AND CHARGES**

**Section 701. Public Utility Basis; Fiscal Year.** The System shall be operated and maintained by the Township on a public utility basis pursuant to state law under the supervision and control of the Township Board, subject to the terms of the Contract. The Township Board may employ such person or persons in such capacity or capacities as it deems advisable to continue the efficient management and operation of the System and may make such rules, orders and regulations as it deems advisable and necessary to assure the efficient management and operations of the System. The System shall be operated on an April 1 to March 31 fiscal year.

**Section 702. Connection Fee.** The owner of all premises required by Article III to connect to the System shall pay a Connection Fee.

a. **Computation.** The Connection Fee shall be comprised of a rate per Unit, including the Availability Fee, Sewage Treatment Plant Connection Fee, Trunkage Charge, Lateral Charge and other applicable fees and charges, which is established by resolution of the Township Board from time to time.

b. **Cost and Expense of Service Connection.** In addition to the Connection Fee as computed in (a) above, the owner of the premises shall be liable for the costs and expenses of acquiring from the Township and installing the Service Connection pursuant to the then-current Township Standard Specifications for Construction. The Township shall determine the type of Service Connection for each User on the basis of conformity to prior installations and the integrity of the Public Sewer System.

c. **Special Assessments.** Subject to the provisions of Section 702.d. below, those parcels located in a Special Assessment District and subject to a full special assessment on the Special Assessment Roll shall be deemed to have paid the Connection Fee and, if applicable,

the cost of acquiring and installing the Service Connection; provided, however, that such credit shall not result in a full or partial refund of the special assessment paid or payable pursuant to the Special Assessment Roll, unless specifically established by the Township at the time the Special Assessment Roll was confirmed by the Township; provided further that a partial special assessment (levied for example, on a vacant lot) shall be offset against the Connection Fee and, if applicable, the cost of acquiring a Service Connection.

d. **Non-residential Users.** The Connection Fee for non-residential Users shall be based upon either (1) meter size, or (2) the number of Units assigned to such premises based on equivalent Units determined by the Township using historical data for similar uses, or if not such uses exist, by the Table of Unit Factors attached as Appendix III.

e. **Installment Payment.** A single family residential building which includes two or fewer Dwelling Units required or electing to connect, for which an application for Service Connection Permit is filed with the Township prior to the expiration of the twelve (12) month connection period provided by Section 305 shall be entitled to pay the certain components of the Connection Fee (namely, the Availability Fee, Trunkage Charge and Lateral Charge, but not the Sewage Treatment Plant Connection Fee) determined in accordance with Section 702.a. to the extent not offset by a credit for a special assessment in accordance with Section 702.c., in equal annual installments of principal, plus interest on the unpaid balance, pursuant to the terms of a written agreement to be entered between the Township and said User providing for annual installment payments to the Township for a period of years at a specified rate of interest. The first installment shall be due and payable prior to the issuance of a permit for a Service Connection in accordance with Section 502.

f. **Cash Payment.** Except for installment payments permitted by the terms of Section 702.e. above, the Connection Fee shall be paid in full, to the extent not offset by a credit, prior to the issuance by the Township of a Service Connection permit to connect to the Public Sewer System pursuant to Article V.

### **Section 703. User Charge.**

a. **Computation.** A User Charge shall be charged to each premises within the Service District connected to the Public Sewer System as follows:

(1) **Readiness to Serve Charge:** a rate per quarter per Unit established by resolution of the Township Board from time to time.

(2) **Commodity Fee:** A rate per 1,000 gallons established by resolution of the Township Board from time to time.

(3) **Debt Service Charge:** a rate per quarter per Unit established by resolution of the Township Board from time to time.

b. **Normal Strength Domestic Sewage.** The User Charge imposed pursuant to this Section are applicable only to Users who discharge Normal Strength Domestic Sewage. A User who discharges toxic pollutants or Sewage into the System that does not qualify as Normal Strength Domestic Sewage shall also pay a User Surcharge determined pursuant to Section 704 below.

c. **Accrual Date.** The User Charge, including the Readiness to Serve Charge and Debt Service Charge, shall begin to accrue with respect to an existing structure as of the date of the connection of the Building Sewer to the Public Sewer System in accordance with Article V, above and with respect to a new structure upon the date of issue of an occupancy permit. If appropriate, the billing of said charges for the initial billing period shall be pro rated in arrears.

d. **Responsibility of User to Pay for Service Connection Power.** In addition to the User Charge, each User shall provide and pay for the electrical power necessary for the operation of their individual Service Connection, which is a Grinder Pump System, as such electrical power is independently metered and billed.

e. **Change in Use.** After connection of a premises to the System, subsequent changes in the character of use or type of occupancy of the premises shall not abate the obligation of the User to pay the User Charge for the premises based upon the number of Units originally allocated thereto, unless and until the Township determines that the number of Units allocated to such premises shall be increased or decreased based upon such changes in use or occupancy.

f. **Unoccupied Premises.** A User Charge shall not be charged to a premises which is not used for a period of twelve (12) consecutive months (which fact shall be established to the reasonable satisfaction of the Township). The sewer service for such premises shall be turned off by the Township and the appropriate Miscellaneous User Fee shall be paid by the User.

**Section 704. User Surcharge.** The User Surcharge payable pursuant to Section 703.b. above, shall be an amount sufficient to provide for the proportional distribution of the increased expense of cost of operation and maintenance of the system. Factors such as Sewage strength, volume, discharge flow rate characteristics and the increased expense of the System for the transportation and treatment of non-qualifying Sewage shall be considered and included as a basis for determining the User Surcharge.

**Section 705. Miscellaneous User Fee.** The Township shall, from time to time, establish by resolution of the Township Board and impose on one or more Users a Miscellaneous User Fee, as necessary, for miscellaneous service, repairs and related administrative costs associated with the System and incurred, without limitation, as a result of the intentional or negligent acts of such User or Users, including for example, excessive inspection services not covered by the Inspection and Administration Fee, costs of repairing and/or replacing a damaged Service Connection, costs of abating a nuisance pursuant to Section 1105 hereof, and costs incurred by the Township to shut off and turn on sewer service.

**Section 706. Inspection and Administration Fee.** The Inspection and Administration Fee shall be determined from time to time by resolution of the Township Board and shall be based upon the actual cost borne by the Township for its Inspectors.

**Section 707. Billing of Sewer Rates and Charges.**

a. The Township shall bill and collect all Sewer Rates and Charges on a quarterly basis on the following schedule of billing dates and due dates:

b. Sewer Rates and Charges shall be billed quarterly. Meters will typically be read by the 15th of the month for each quarter, and bills will be sent out, thereafter, to be received



by a User on or around the 22nd of that month. Payment will be due on or before the 15th of the following month, however holidays may change due dates for convenience. A User whose bill is not paid on or before the due date shall have a penalty charged based on the Township's fee schedule, added thereto and shall be mailed a reminder approximately one week after the due date for the quarterly bill. The reminder bill will notify the User that the entire payment must be paid in full within two weeks, or the User's sewer service will be shut off. A sewer service shut off notice will also be posted on the Premises 72 hours prior to the shut off. If the sewer service is shut off, sewer service shall not be restored until the entire balance has been paid in full. Under special circumstances and in the sole discretion of the Township, the Township and the User may agree to a payment plan for the payment of any past due amounts, which will suspend the shut off and the accrual of penalty charges, provided the User makes the required monthly payments pursuant to the payment plan. Provided that a User is in compliance with all other provisions of this Ordinance, the Township will not shut off a User's service if the User owes less than \$100 in past due sewer bills. Bills and notices will be mailed to the address listed on the sewer permit application filed with the Township unless a change of address has been filed in writing at the business office of the Township. No person shall be excused from payment of a bill by reason of non-delivery of such bill or notice. Payment of said bill shall be made at the Township business office. The Township may choose to bill monthly or to stagger billing if so desired.

c. The bill shall separately itemize the Sewer Rates and Charges. All Users will receive an annual notification either printed on the bill or enclosed in a separate letter or notice which will show the breakdown of the sewer bill in its components for operation, maintenance and replacement and for debt retirement.

d. Payment of said bill shall be made at a location and in a manner designated by the Township.

**Section 708. Unpaid Sewer Rates and Charges; Penalty.** If Sewer Rates and Charges are not paid on or before the due date then a penalty in the amount of 10% shall be added to the balance due.

**Section 709. Unpaid Sewer Rates and Charges; Remedies.** If Sewer Rates and Charges are not paid on or before the due date, the Township, pursuant to Act 178 of the Public Acts of Michigan of 1939, as amended, may

a. discontinue the services provided by the System by either disconnecting the Building Sewer from the Service Connection or, if the premises is connected to the Township's public water system, then disconnection for the public water system, and the service so discontinued shall not be reinstated until all sums then due and owing, including time price differential, penalties, interest and all expenses incurred by the Township for shutting off and turning on the service, shall be paid to the Township;

b. institute an action in any court of competent jurisdiction for the collection of the amounts unpaid, including penalties, interest and reasonable attorney fees; or

c. enforce the lien created in Section 710 below.

These remedies shall be cumulative and shall be in addition to any other remedy provided in this Ordinance or now or hereafter existing at law or equity.

Under no circumstances shall action taken by the Township to collect unpaid Sewer Rates and Charges, penalties and interest, invalidate or waive the lien created by Section 710 below. Before disconnecting service, the Township shall give thirty (30) days written notice to the User at the last known address according to the Township records and the Township Tax Assessment Roll. The notice shall inform the User that the User may request an informal hearing to present reasons why service should not be disconnected.

**Section 710. Lien.** The Sewer Rates and Charges shall be a lien on the respective premises served by the System. Whenever Sewer Rates and Charges shall be unpaid for six (6) months or more, they shall be considered delinquent. The Township shall certify all Sewer Rates and Charges delinquent as of March 16 and penalties thereon, annually, on or before October 1, of each year, to the tax assessing officer of the Township, who shall enter the delinquent Sewer Rates and Charges, interest and penalties, together with an additional penalty equal to 10% of the total, upon the next tax roll as a charge against the premises affected and such charge shall be collected and the lien thereof enforced in the same manner as ad valorem property taxes levied against such premises.

**Section 711. No Free Service.** No free service shall be furnished by the System to any Person, public or private, or to any public agency or instrumentality.

**Section 712. Rental Properties.** A lien shall not attach for Sewer Rates and Charges to a Premises which is subject to a legally executed lease that expressly provides that the tenant (and not the landlord) of the premises or a dwelling unit thereon shall be liable for payment of Sewer Rates and Charges, effective for services which accrue after the date an affidavit is filed by the landlord with the Township. This affidavit shall include the names and addresses of the parties, the expiration date of the lease and an agreement by the landlord to give the Township thirty (30) days written notice of any cancellation, change in or termination of the lease. The filing of the affidavit by the landlord shall be accompanied by a true copy of the lease and a security deposit in the amount equal to the User Charge for the preceding four (4) quarterly billing periods. Upon the failure of the tenant to pay the Sewer Rates and Charges when due, the security deposit shall be applied by the Township against the unpaid balance, including interest and penalties. The tenant shall immediately make sufficient payment to the Township to cover the amount of the security deposit so advanced. Upon the failure of the tenant to do so within ten (10) days of said advance, the penalties, rights and remedies set forth in Section 709 and Section 710 of this Article shall be applicable with respect to the unpaid Sewer Rates and Charges, including interest and penalties. The security deposit shall be held by the Township without interest and shall be returned to the landlord upon proof of termination of the lease.

**Section 713. Cancellation of Permits; Disconnection of Service.** Applications for connection permits may be canceled and/or sewer service discontinued or disconnected by the Township for any violation of any part of this Ordinance, including, without limitation, any of the following reasons:

a. Misrepresentation in the permit application as to the nature or extent of the property to be serviced by the System.

- b. Nonpayment of Sewer Rates and Charges.
- c. Failure to keep Building Sewers and Sampling Manholes in a suitable state of repair.
- d. Discharges in violation of this Ordinance.
- e. Damage to any part of the System.

Sewer service shall not be restored until the entire amount of the sewer bill has been paid together with any applicable penalty charged, and a restoration charge, which shall be established and adjusted from time to time by resolution of the Township Board, has been paid.

**Section 714. Security Deposit.** If the sewer service supplied to a User has been discontinued for nonpayment of Sewer Rates and Charges, service shall not be reestablished until all delinquent Sewer Rates and Charges, interest and penalties, and the turn on charge has been paid. The Township may, as a condition to reconnecting said service, request that a sum equal to the User Charge for the preceding four (4) quarterly billing periods be placed on deposit with the Township for the purpose of establishing or maintaining any User's credit. Said deposit shall not be considered in lieu of any future billing for Sewer Rates and Charges. Upon the failure of the User to pay the Sewer Rates and Charges when due, the security deposit shall be applied by the Township against the unpaid balance, including interest and penalties. The User shall immediately make sufficient payment to the Township to reinstate the amount of the security deposit so advanced. Upon the failure of the User to do so within ten (10) days of said advance, the penalties, rights and remedies set forth in Section 709 and Section 710 of this Article shall be applicable with respect to any unpaid Sewer Rates and Charges, including interest and penalties. The security deposit shall be held by the Township without interest and shall be returned to the User upon continued timely payments by the User of all Sewer Rates and Charges as and when due, for a minimum of four (4) consecutive quarters.

**Section 715. Billing Address.** Bills and notices relating to the conduct of the business of the Township will be mailed to the User at the address listed on the permit application filed pursuant to Article V unless a change of address has been filed in writing at the business office of the Township; and the Township shall not otherwise be responsible for delivery of any bill or notice, nor will the User be excused from non-payment of a bill or from any performance required in said notice.

**Section 716. Interruption of Service; Claims.** The Township shall make all reasonable efforts to eliminate interruption of service, and when such interruption occurs, will endeavor to reestablish service with the shortest possible delay. Whenever service is interrupted as a result of work on the System, all Users affected by such interruption will be notified in advance whenever it is possible to do so. The Township shall, in no event, be held responsible for claims made against it by reason of the breaking of any mains or service pipes, or by reason of any other interruption of the service caused by the breaking of machinery or stoppage for necessary repairs; and no person shall be entitled to damages nor have any portion of a payment refunded for any interruption.

## ARTICLE VIII REVENUES

**Section 801. Estimated Rates; Sufficiency.** The User Charges hereby fixed are established to be sufficient to provide for the cost of Operation and Maintenance of the System as are necessary to preserve the same in good repair and working order. Such rates shall be fixed and revised by resolution of the Township Board from time to time as may be necessary to produce these amounts. An annual audit shall be prepared. Based on this audit, rates for sewage services shall be reviewed annually and revised as necessary to meet system expenses and to insure that all User Classes pay their proportionate share of the Cost of Operation and Maintenance.

**Section 802. Revenues; Depository.** The revenues of the System shall be deposited as follows:

a. Except to the extent required by Section 802.b. all Revenues of the System shall be deposited into a separate depository bank account entitled “SEWER OPERATING AND MAINTENANCE FUND” and allocated to separate subaccounts in the following manner:

(1) **Operation and Maintenance Account.** On a quarterly basis, adequate revenues from the collection of User Charges sufficient to provide for the payment of the next quarter’s current expenses of administration and operation of the System and such current expenses for the maintenance of the System to preserve the System in good repair and working order shall be deposited to the Operation and Maintenance Account.

(2) **Improvement Account.** There shall next be established and maintained an account, designated “Improvement Account,” which shall be used for the purpose of making improvements in the efficiency of the System through the use of new technology and the replacement or repair of obsolete or inefficient components to prevent overburdening of or failures in the System. There shall be set aside into said fund, after provision has been made for the Operation and Maintenance Account, such revenues derived from User Charges and other revenues as the Township Board shall deem necessary for this purpose.

(3) **Payback Account.** There shall next be established and maintained an account, designated “Payback Account,” which shall include separate subaccounts for each of the Township’s contractual payment obligations, exclusive of debt service on bonds issued by or on behalf of the Township which are provided for in Section 802.b., below. The Payback Account shall include, without limitation, separate subaccounts to provide for payment of the contractual payments derived from the proceeds of certain Connection Fees payable to the extent and in the manner provided in any development agreement(s) and any payback agreement entered in to by the Township and a developer, if any, in accordance therewith.

(4) **System Extensions Fund.** There shall next be established and maintained a “System Extension Fund” for the purpose of making extensions and enlargements to the System. Where the Township has utilized System revenues for the enlargement or extension of the System to provide service to a new User of the System,

the Connection Fee paid by the new User shall be deposited into the Extension Fund and used by the Township to repay the costs for the enlargement or extension of the Public Sewer System to serve that User. To the extent that there are any unused funds derived from Connection Fees remaining in the Extension Fund after the costs for enlargement or expansion of the Public Sewer System have been paid, the unused funds shall be deposited in the System Improvement Account.

(5) **Surplus Account.** Collections of System revenues not allocated to one of the above described accounts or to a debt service fund or account in accordance with Section 802.b. shall be allocated to the “Surplus Account.” The funds on deposit in the Surplus Account may be used for any lawful purpose related to the System.

b. For the payment of debt service on bonds issued by or on behalf of the Township with respect to the System, there shall be established and maintained a separate depository account, to be designated the “System Contract Payment Fund,” which shall be used solely for the payment of the Township’s obligations to the County pursuant to the Contract to enable the County to retire the County issued bonds for the System. There shall be deposited in said fund periodically all collections of connection fees and payments for connections to the System derived from Users of the System, in order to pay the Township’s contractual obligations when due to the County. Should such revenues prove insufficient for this purpose, such revenues may be supplemented by any other funds of the Township legally available for such purpose.

c. All other revenues of the System, to the extent the handling of said revenues are not expressly provided for by the terms of subsections a. and b., shall be set aside, as collected, and deposited into a separate depository account in a bank duly qualified to do business in Michigan, in an account to be designated Jamestown Sewer System Receiving Fund (the “Receiving Fund”), and said revenues so deposited shall be transferred from the Receiving Fund periodically in the manner and at the time herein specified.

d. **Bank Accounts.** All moneys belonging to any of the foregoing funds or accounts may be kept in one bank account, in which event the moneys shall be allocated on the books and records of the Township within this single bank account, in the manner above set forth.

**Section 803. Transfer of Funds.** In the event the moneys in the System Receiving Fund are insufficient to provide for the current requirements of the System Operation and Maintenance Fund any moneys and/or securities in other funds of the System, subject to the restrictions if any of the Contract, shall be transferred to the appropriate operation and maintenance fund, to the extent of any deficit therein and these monies shall be replaced in the next operating year.

**Section 804. Investment of Funds.** Moneys in any fund or account established by the provisions of this Ordinance may be invested in the manner provided in the Township Investment Policy, subject to the limitations set forth in Act 94, Public Acts of Michigan of 1933, as amended. Income received from such investments shall be credited to the fund from which said investments were made.

**ARTICLE IX**  
**ADMINISTRATIVE APPEALS; BOARD OF APPEALS**

**Section 901. Informal Hearing.** In order that the provisions of this Ordinance may be reasonably applied and substantial justice done in instances where this Ordinance is misapplied or unnecessary financial hardship would result from carrying out the strict letter of this Ordinance, an informal hearing before the Supervisor may be requested in writing by any Person deeming itself aggrieved by a citation, order, charge, fee, surcharge, penalty or action within thirty (30) days after the date thereof, stating the reasons therefore with supporting documents and data. The informal hearing shall be scheduled at the earliest practicable date, but not later than thirty (30) days after receipt of the request, unless extended by mutual written agreement. The hearing shall be conducted on an informal basis at the Township Hall or at such place as designated by the Supervisor. The Supervisor may grant the appeal, reject the appeal or schedule a second informal hearing not more than 10 days after the initial hearing to allow time for study or to gather additional information. The Supervisor shall issue a written statement of his decision within fifteen (15) business days after the informal hearing.

**Section 902. Board of Appeals.** In order that the provisions of this Ordinance may be reasonably applied and substantial justice done in instances where this Ordinance is misapplied or unnecessary hardship would result from carrying out the strict letter of this Ordinance, the Township Board shall serve as a Wastewater Board of Appeals. The duty of such Board shall be to consider appeals from the decision of the Supervisor and to determine, in particular cases, whether this Ordinance has been misapplied or any deviation from strict enforcement will violate the intent of the Ordinance or jeopardize the public health or safety. In all appeals, the appellant shall have the burden of proof.

**Section 903. Appeals from Informal Hearing.** Appeals from the written decisions of the Supervisor may be made to the Township Board, acting as a Board of Appeals, within thirty (30) days from the date of the written decision of the Supervisor. Such appeal may be taken by any Person aggrieved. The appellant shall file a Notice of Appeal with the Supervisor and with the Board, specifying the ground therefor. Prior to a hearing, the Supervisor shall transmit to the Board a summary report of all previous action taken. The Board may, at its discretion, call upon the Supervisor to explain the action. The final disposition of the appeal shall be in the form of a resolution, either reserving, modifying, or affirming, in whole or in part, the appealed decision or determination. In order to find for the appellant, a majority of the Board must concur. The Board of Appeals shall fix a reasonable time for the hearing of the appeal, give due notice thereof to interested parties, and decide the same within a reasonable time. Within the limits of its jurisdiction, the same Board of Appeals may reserve or affirm, in whole or in part, or may make such order, requirements, decision or determination as, in its opinion, ought to be made in the case under consideration, and to that end have all the powers of the official from whom said appeal is taken. The decision of said Board shall be final.

The Board of Appeals shall meet at such times as the Board may determine. There shall be a fixed place of meeting and all meetings shall be open to the public in accordance with applicable laws. The Board shall adopt its own rules or procedure and keep a record of its proceedings, showing findings of fact, the action of the Board, and the vote of each member upon each question considered. The presence of four (4) members shall be necessary to constitute a quorum.

**Section 904. Payment of Amounts Outstanding.** All Sewer Rates and Charges outstanding during any appeal process shall be due and payable to the Township. Upon resolution of any appeal, the Township shall adjust such amounts accordingly; however, such adjustments shall be limited to the previous one year's billing unless otherwise directed by court order.

**Section 905. Effect of Administrative Action.** If any informal or formal hearing is not demanded within the periods specified herein, such administrative action shall be deemed final. In the event either or both such hearings are demanded, the action shall be suspended until a final determination has been made, except for immediate cease and desist order issued pursuant to this Ordinance.

**Section 906. Appeal from Board of Appeals.** Appeals from the determinations of the Board of Appeals may be made to the Circuit Court for the County of Ottawa within twenty (20) days as provided by law. Such appeals shall be governed procedurally by the Administrative Procedures Act of the State of Michigan, Act 306 of the Public Acts of Michigan of 1969, as amended. All findings of fact, if supported by the evidence, made by the Board shall be conclusive upon the Court.

## **ARTICLE X NOTICE AND CLAIM PROCEDURES FOR SEWER OVERFLOW OR BACKUP**

**Section 1001. Notice and Claim Procedures Applicable to Overflow or Backup of the Public Sewer System.** This section has been adopted in accordance with Act 222 of the Public Acts of Michigan of 2001 ("Act 222") to set forth the notice and claim procedures applicable to an overflow or backup of the Public Sewer System, which, as defined in Act 222, shall be referred to for purposes of this Article as a "Sewage Disposal System Event." To afford property owners, individuals and the Township greater efficiency, certainty and consistency in the provision of relief for damages or physical injuries caused by a Sewage Disposal System Event, the Township and any Person making a claim for economic damages, which, as defined in Act 222, shall be referred to for purposes of this Section as a "Claimant," shall follow the following procedures:

a. A Claimant is not entitled to compensation unless the Claimant notifies the Township of a claim of damage or physical injury, in writing, within 45 days after the date the damage or physical injury was discovered by the Claimant, or in the exercise of reasonable diligence should have been discovered by the Claimant.

b. The written notice under subsection a. shall contain the Claimant's name, address, and telephone number, the address of the affected property, the date of discovery of any property damages or physical injuries, and a brief description of the claim. As part of the description of the claim, the Claimant shall submit an explanation of the Sewage Disposal System Event and reasonable proof of ownership and the value of any damaged personal property. Reasonable proof of ownership and the purchase price or value of the property may include testimony or records. Reasonable proof of the value of the property may also include photographic or similar evidence.

c. The written notice under subsection a. shall be sent to the Township Supervisor, who is hereby designated as the individual at the Township to receive such notices pursuant to Section 19 of Act 222.

d. If a Claimant who owns or occupies affected property notifies the Township orally or in writing of a Sewage Disposal System Event before providing a notice of a claim that complies with subsections a., b. and c., the Township Supervisor shall provide the Claimant with a written explanation of the notice requirements of subsections a., b., and c., sufficiently detailed to allow the Claimant to comply with said requirements.

e. If the Township is notified of a claim under subsection a. and the Township believes that a different or additional governmental agency may be responsible for the claimed property damages or physical injuries, the Township shall notify the contacting agency of each additional or different governmental agency of that fact, in writing, within 15 business days after the date the Township receives the Claimant's notice under subsection a.. The Township shall give notice of a claim to the County.

f. If the Township receives a notice from a Claimant or a different or additional governmental agency that complies with this Section, the Township may inspect the damaged property or investigate the physical injury. A Claimant or the owner or occupant of affected property shall not unreasonably refuse to allow the Township or its duly authorized representatives to inspect damaged property or investigate a physical injury.

g. Prior to a determination of payment of compensation by the Township, the Claimant shall provide to the Township additional documentation and proof that:

(1) At the time of the Sewage Disposal System Event, the Township owned or operated, or directly or indirectly discharged into, that portion of the Public Sewer System that allegedly caused damage or physical injury;

(2) The Public Sewer System had a defect;

(3) The Township knew, or in the exercise of reasonable diligence, should have known, about the defect in the Public Sewer System;

(4) The Township, having the legal authority to do so, failed to take reasonable steps in a reasonable amount of time to repair, correct or remedy the defect in the Public Sewer System; and

(5) The defect in the Public Sewer System was a proximate cause that was 50% or more of the cause of the Sewage Disposal System Event and the property damage or physical injury.

h. Prior to a determination of payment of compensation by the Township, the Claimant shall also provide to the Township additional documentation and proof that neither of the following were a proximate cause that was 50% or more of the cause of the Sewage Disposal System Event:



An obstruction in a Service Connection or a Building Sewer that was not caused by the Township; or,

A connection on the affected premises, including, but not limited to, a footing drain, sump system, surface drain, gutter, down spout or connection of any other sort that discharged any storm water, surface water, ground water, roof runoff, sub surface drainage, cooling water, unpolluted air conditioning water or unpolluted industrial process waters to the Public Sewer System.

i. If the Township and a Claimant do not reach an agreement on the amount of compensation for the property damages or physical injury within 45 days after the receipt of notice under subsection a., the Claimant may institute a civil action in accordance with Act 222.

j. To facilitate compliance with this Section, the Township shall make available to the public information about the notice and claim procedures under this Section.

k. The notice and claim procedures set forth in this Section shall be applicable to a Sewage Disposal System Event involving the Public Sewer System.

l. The Township does not own or operate any Storm Sewer, Storm Drain or combined sewer and, accordingly, the notice and claim procedures set forth in this Section, with the exception of subsection e., do not apply to a Sewage Disposal System Event involving a Storm Sewer, Storm Drain or a combined sewer.

m. In the event of a conflict between the notice and claim procedures set forth in this Section and the specific requirements of Act 222, the specific requirements of Act 222 shall control.

n. As provided in Section 19(7) of Act 222, the notice and claim procedures of this Section do not apply to claims for non-economic damages (as defined in Act 222) arising out of a Sewage Disposal System Event.

o. Any word, term or phrase used in this Section, if defined in Act 222, shall have the same meaning provided under Act 222.

## **ARTICLE XI ENFORCEMENT**

**Section 1101. Inspection by Township.** The duly authorized representatives, employees or agents of the Township, the City, and the County, including, but not limited to, the Inspector, the Township Supervisor, the Township Engineer, the County's Director of Public Utilities, the Health Department, and representatives of EGLE bearing proper identification shall be permitted to enter at any time during reasonable or usual business hours in and upon all properties in the Service District for the purposes of inspection, observation, measurement, sampling, testing and emergency repairs in accordance with the provisions of this Ordinance. Any Person who applies for and receives sewer services from the Township or owns real property in the Service District shall be deemed to have given consent for all such activities including entrance upon that Person's property.

**Section 1102. Damage to System.** No unauthorized Person shall maliciously, willfully, or negligently break, damage, destroy, uncover, deface, or tamper with, climb upon, or enter into any structure, appurtenance, or equipment of the Public Sewer System.

**Section 1103. Notice to Cease and Desist.** Except for violations of Section 1102 hereof, any Person found to be violating any provision of this Ordinance shall be served by the Township with written notice stating the nature of the violation and providing a reasonable time limit for the satisfactory correction thereof. The offender shall, within the period of time stated in such notice, permanently cease all violations.

**Section 1104. Civil Infraction.** Any violation of Section 1102, or any violation beyond the time limit provided for in Section 1103, shall be a municipal civil infraction, for which the fine shall not be less than \$100 nor more than \$500 for the first offense and not less than \$200 nor more than \$2,500 for subsequent offenses, in the discretion of the Court, and in addition to all other costs, damages, and expenses provided by law. For purposes of this section, “subsequent offense” means a violation of this Ordinance committed by the same person within 12 months of a previous violation of the Ordinance for which said person admitted responsibility or was adjudicated to be responsible, provided, however, that offenses committed on subsequent days within a period of one week following issuance of a citation for a first offense shall all be considered separate first offenses. Each day that such violation occurs shall constitute a separate offense. Any person violating any of the provisions of this Ordinance shall, in addition, become liable for any expense, including reasonable attorney fees, loss, or damage occasioned by reason of such violation. The Supervisor is hereby authorized to issue, in the manner provided by law, citations for municipal civil infractions for violations of this Ordinance.

**Section 1105. Nuisance; Abatement.** Any Nuisance or any violation of this Ordinance is deemed to be a nuisance per se. The Township in the furtherance of the public health may enforce the requirements of this Ordinance by injunction or other remedy and is hereby empowered to make all necessary repairs or take other corrective action necessitated by such nuisance or violation. The Person who violated the Ordinance or permitted such nuisance or violation to occur shall be responsible to the Township for the costs and expenses, including reasonable attorney fees, incurred by the Township in making such repairs or taking such action as a Miscellaneous User Fee.

**Section 1106. Liability for Expenses.** Any Person violating any of the provisions of this Ordinance shall become liable to the Township and their authorized representatives for any expense including, but not limited to, the Township’s actual attorney’s fees, loss, or damage incurred by the Township (including repair or replacement costs) by reason of such violation.

**Section 1107. Remedies are Cumulative.** The remedies provided by this Ordinance shall be deemed to be cumulative and not mutually exclusive with any other remedies available to the Township.

**ARTICLE XII  
MISCELLANEOUS**

**Section 1201. Repeal of Conflicts.** All ordinances or parts of ordinances in conflict herewith and relating to the Public Sewer System are hereby repealed.

**Section 1202. Severability.** The validity of any Section, clause, sentence, or provision of this Ordinance shall not affect the validity of any other part of this Ordinance which can be given effect without such invalid part or parts.

**Section 1203. State and Federal Law Requirements.** If any provision of applicable state or federal law imposes greater restrictions than are set forth in this Ordinance then the provisions of such state or federal law shall control.

**Section 1204. Article and Section Headings.** The Article and Section headings used in this Ordinance are for convenience of reference only and shall not be taken into account in construing the meaning of any portion of this Ordinance.

**Section 1205. Reservation of Right to Amend.** Subject to the provisions of the Contract, the Township specifically reserves the right to amend this Ordinance in whole or in part, at one or more times hereafter, or to repeal the same, and by such amendment to repeal, abandon, increase, decrease, or otherwise modify any of the Sewer Rates and Charges herein provided.

**ARTICLE XIII  
PUBLICATION AND EFFECTIVE DATE**

**Section 1301. Publication.** A true copy or a summary of this Ordinance shall be published in *The Grand Rapids Press*, a newspaper of general circulation within the boundaries of the Township qualified under state law to publish legal notices within thirty (30) days after the adoption of the Ordinance by the Township. This Ordinance shall be recorded in the minutes of the Township Board of the meeting at which this Ordinance was adopted and, in addition, shall be recorded in the Ordinance Book of the Township.

**Section 1302. Effective Date.** This Ordinance shall become effective within thirty (30) days of publication.

Passed and adopted by the Township Board of the Charter Township of Jamestown, County of Ottawa, Michigan, on September 18, 2023, and approved by me on September 18, 2023.



\_\_\_\_\_  
Laurie Van Haitsma, Supervisor  
Charter Township of Jamestown

Attest:

  
\_\_\_\_\_  
Candy DeHaan, Township Clerk

**CERTIFICATE OF TOWNSHIP CLERK**

I hereby certify that the foregoing is a true and complete copy of an Ordinance adopted by the Township Board of the Charter Township of Jamestown, County of Ottawa, State of Michigan, at a regular meeting held on September 18, 2023, and that public notice of said meeting was given pursuant to the Open Meetings Act, being Act No. 267 of Public Acts of Michigan of 1976, as amended including in the case of a special or rescheduled meeting, notice by posting at least eighteen (18) hours prior to the time set for said meeting.

I further certify that said Ordinance has been recorded in the Ordinance Book of the Township and such recording has been authenticated by the signatures of the Supervisor and the Township Clerk.

  
\_\_\_\_\_  
Candy DeHaan  
Township Clerk

**CERTIFICATE OF PUBLICATION**

I, the undersigned, Township Clerk of the Charter Township of Jamestown, County of Ottawa, Michigan, hereby certify pursuant to MCL 42.22 that the Sewer Connection, Use and Rate Ordinance (Township Ordinance No. 23-003) or a summary thereof was published in the *Grand Rapids Press* on October 5, 2023.

Dated: 9/26, 2023

  
\_\_\_\_\_  
Candy DeHaan, Township Clerk

# APPENDIX I MAP OF SERVICE DISTRICT

Ottawa County Service Area

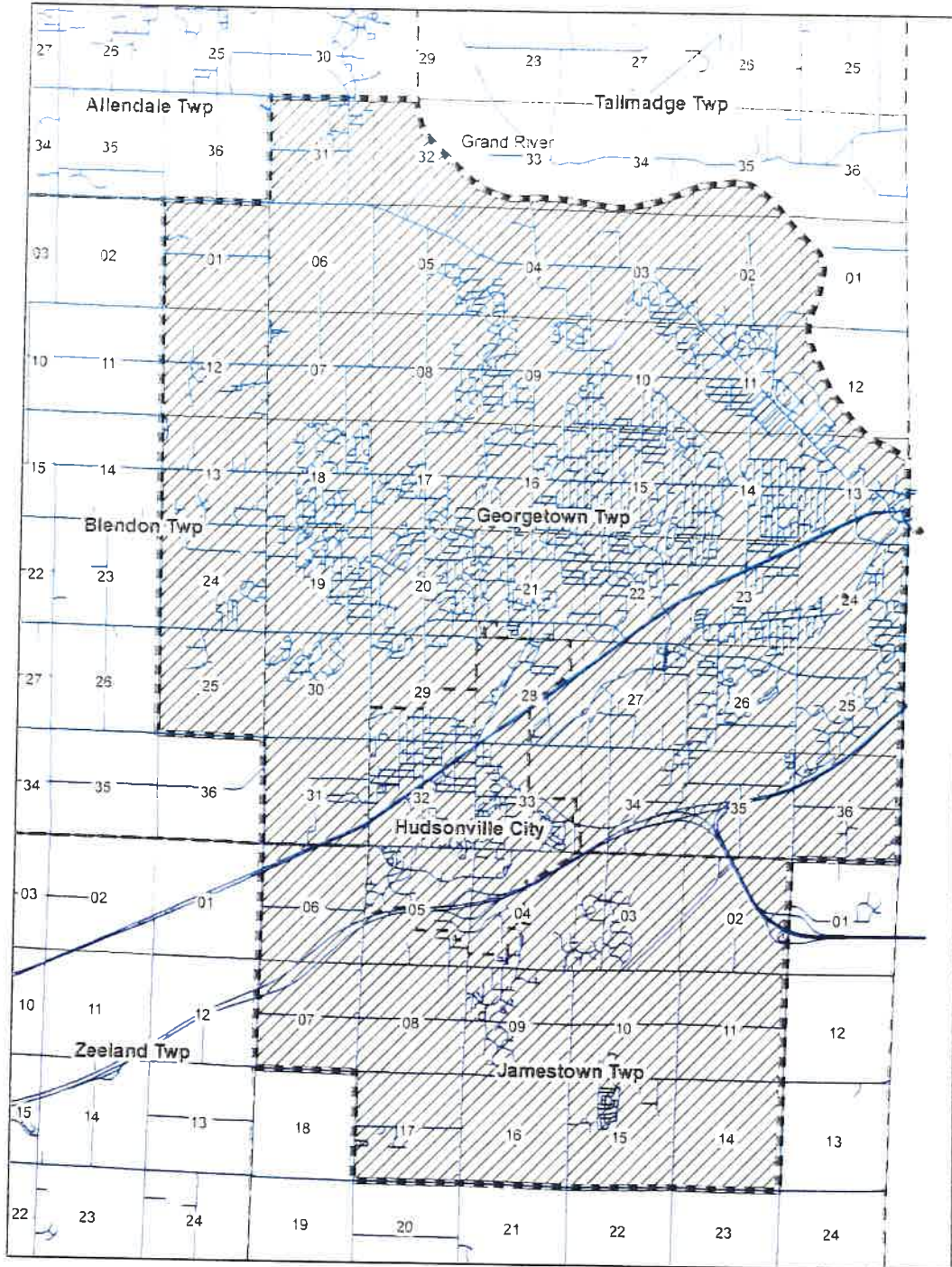

## Legend

 Ottawa County Service Area

**APPENDIX II-A  
DIAGRAM OF GRAVITY SYSTEM**

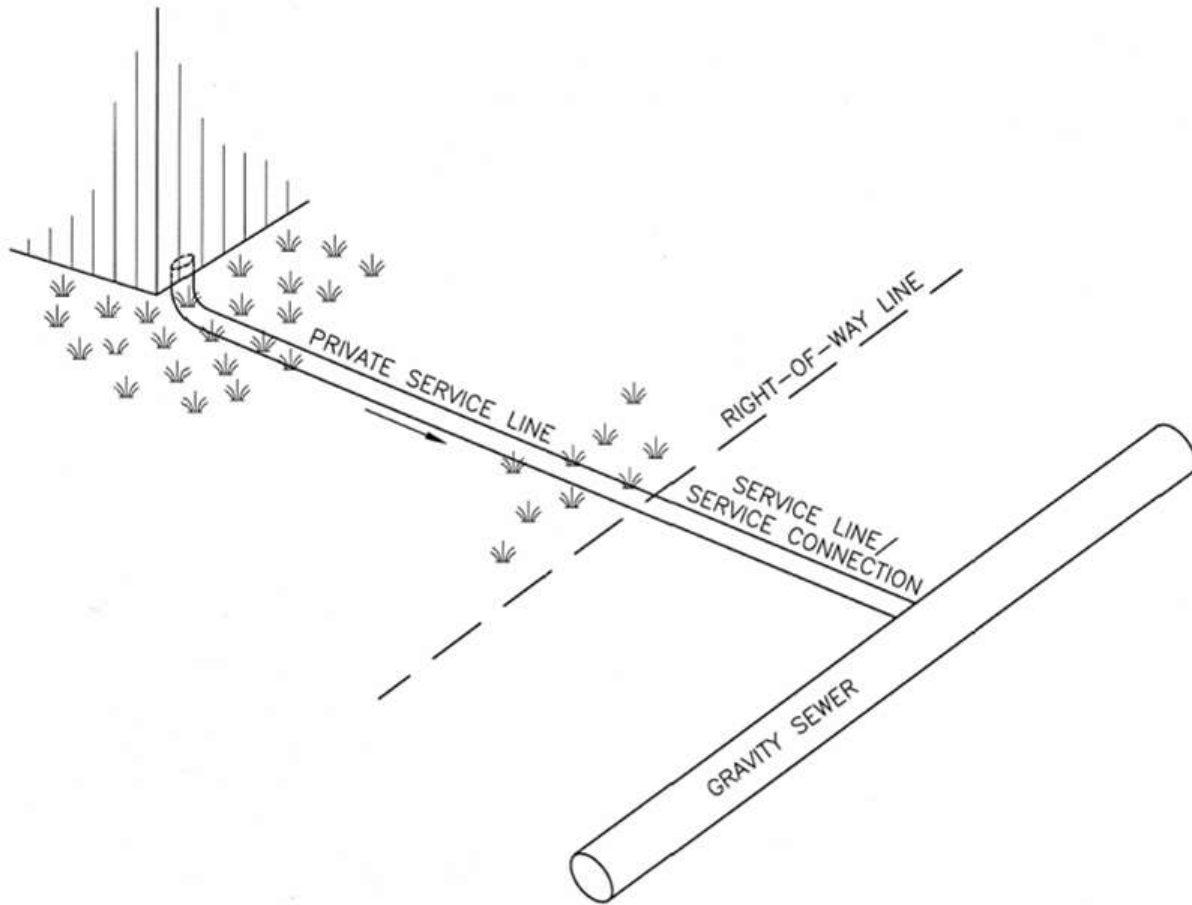

TYPICAL GRAVITY SEWER SCHEMATIC

**APPENDIX II-B  
DIAGRAM OF GRINDER PUMP SYSTEM**

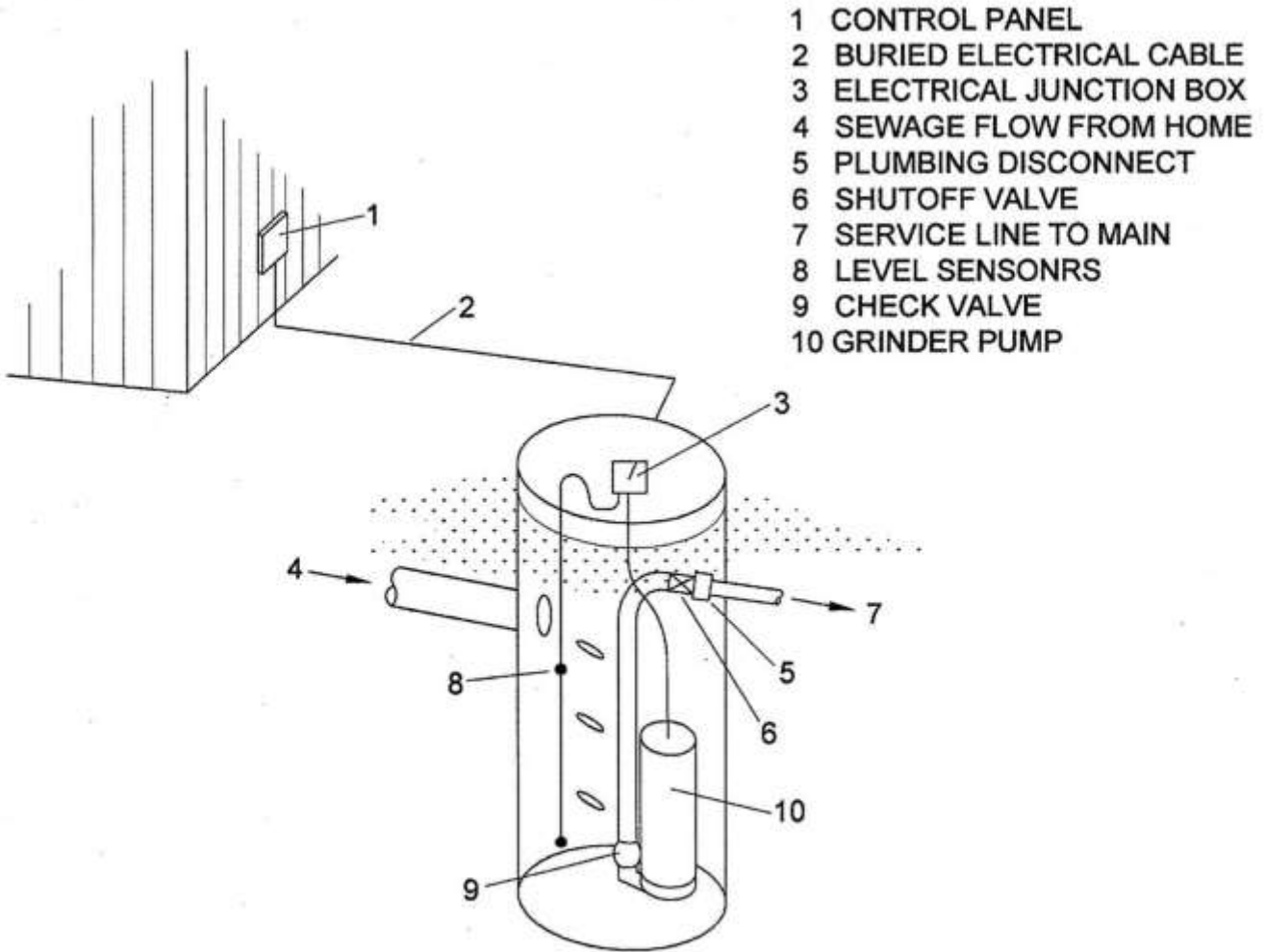

TYPICAL GRINDER PUMP PRESSURE SEWER SCHEMATIC



APPENDIX II-C  
DIAGRAM OF STED SYSTEM

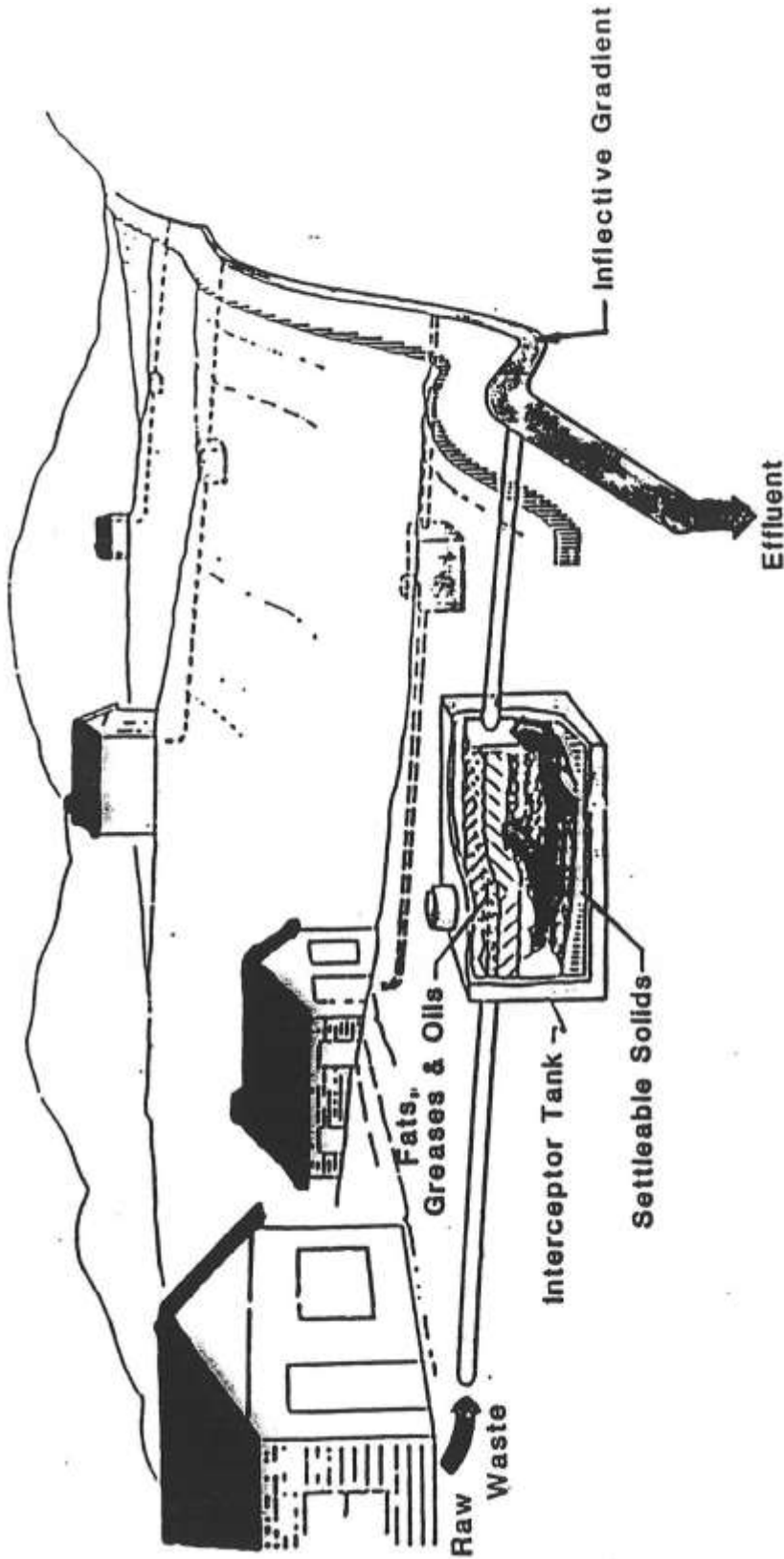

TYPICAL S.T.E.D. EFFLUENT GRAVITY SYSTEM SCHEMATIC

**APPENDIX II-D  
DIAGRAM OF STEP SYSTEM**

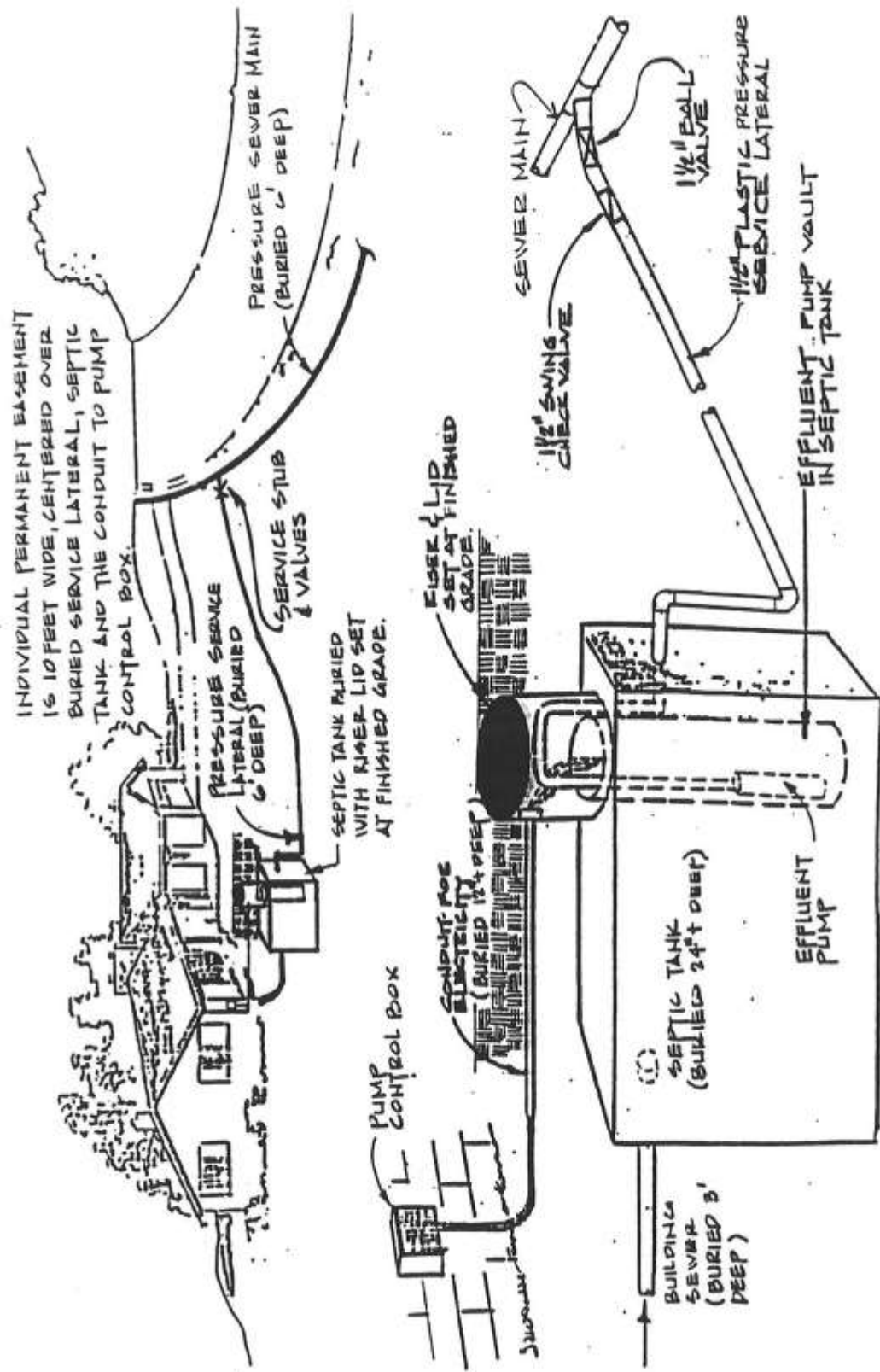

**TYPICAL S.T.E.P. PRESSURE SEWER SYSTEM SCHEMATIC**

**APPENDIX III  
TABLE OF UNIT FACTORS**

USER	RESIDENTIAL EQUIVALENT UNIT FACTOR
Auto Dealer (sales and/or service)	1.00/premise + 0.40/1000 sf
Bakery	1.25/1000 sf
Bank	1.00/1000 sf
Bar	3.00/1000 sf
Barber Shop	1.00/shop + 1.00/1000 sf
Beauty Shop	1.00/shop + 1.00/1000 sf
Boarding House, Boarding School, Dormitory, Fraternity/Sorority, etc.	1.00/premise + 0.25/bedroom
Bowling Alley (with bar and/or restaurant	0.10/alley (bar and restaurant to be computed at their respective equivalent)
Car Wash a) Manual do-it yourself b) Semi-automatic (mechanical without conveyor c) Automatic (with conveyor) d) Automatic (with conveyor, conserving and recycling water)	2.50/stall 10.00/lane 20.00/lane 8.00/lane
Church	0.20/100 sf
Cleaners (pick-up only, no-onsite cleaning or pressing facilities)	1.00/shop
Cleaners (cleaning and pressing facilities)	1.25/premise + 1.00/1000 sf
Condominium	1.00/unit
Convalescent Home	0.22/bed
Convenience Store	1.00/1000 sf
Day Care Center	1.00/premise + 0.25/1000 sf
Drug Store	1.00/1000 sf
Factory (excludes excess industrial use)*	0.50/1000 sf
Fraternal Organization (with bar and/or restaurant)	0.16/hall (bar and restaurant computed at their respective equivalent)

USER	RESIDENTIAL EQUIVALENT UNIT FACTOR
Funeral Home	1.42/1000 sf
Health Club	1.25/1000 sf (swimming pool to be computed at its respective equivalent)
Hospital	1.10/bed
Hotel, Motel	0.40/room
Laundry (self-serve)	0.54/washer
Malls (enclosed)	0.30/1000 sf (extensive water users within Mall such as restaurants and health clubs to be calculated based upon their respective equivalent)
Marina	0.10/slip
Mobile Home, Trailer Park	1.00/unit
Multiple Family Residence (Apartments)	0.75/unit
Office building (general)	0.40/1000 sf
Office Building (medical, dental, clinic, etc.)	1.42/1000 sf
Post Office	1.00/1000 sf
Public Institution – Others	0.75/1000 sf
Restaurant (with bar)	2.50/1000 sf (bar to be computed at its respective residential equivalent)
Restaurant (drive through only)	3.00/1000 sf
Retail Store	1.00/premise + 0.30/1000 sf
Rooming House (no meals)	0.25/bed
School	1.00/classroom (swimming pool to be computed at its respective equivalent)
Service Station/Auto Repair Shop	1.00/premise + 0.40/1000 sf
Single Family Residence	1.00/unit
Snack Bar, Drive-in	4.00/1000 sf
Strip Malls and Businesses with common walls	Minimum of 1 per business + 0.30/1000 sf (extensive water users within Mall such as restaurants and health clubs to be calculated based upon their respective equivalent)
Supermarket, Grocery Store	1.10/1000 sf
Swimming Pool (indoor, including showers)	2.85/1000 sf (water area)

USER	RESIDENTIAL EQUIVALENT UNIT FACTOR
Theater – Drive-In	0.25/1000 sf (of service buildings)
Theater – Indoor	2.00/theater
Travel Trailer Parks and Campgrounds	0.20/site
Two-Family Residence	2.00/building
Utility Sub-Station	0.10/1000 sf
Veterinary Facility	1.50/premise
Veterinary Facility with Kennel	1.50/premise + 0.50/kennel
Warehouse or Storage Building	0.10/1000 sf
Waste Disposal Station	2.00/station